

# DJI DOCK 2

## MATRICE 3D SERIES

### Maintenance Manual

v1.0 2024.04

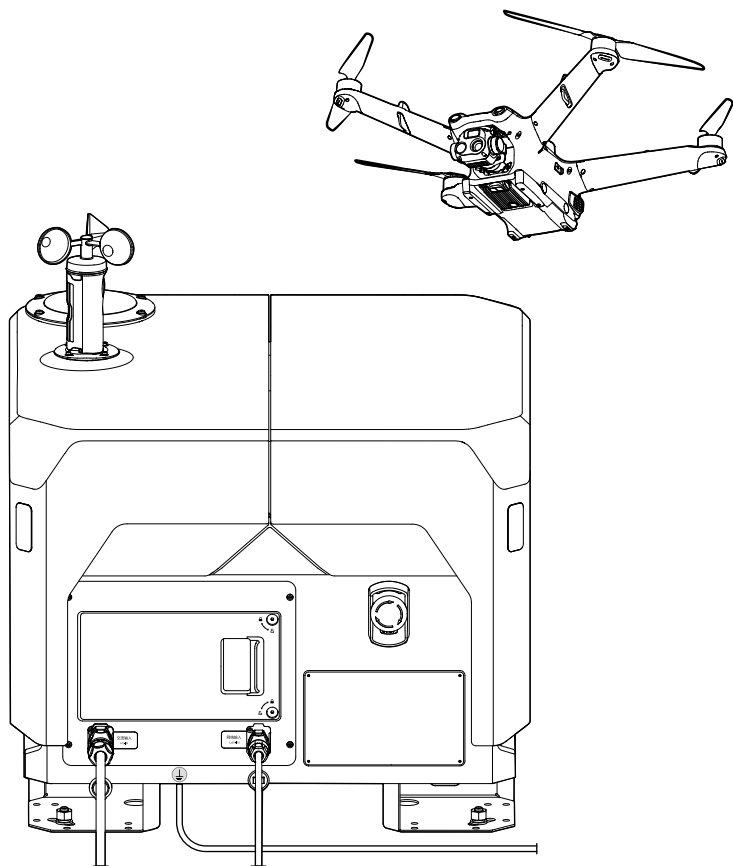



This document is copyrighted by DJI with all rights reserved. Unless otherwise authorized by DJI, you are not eligible to use or allow others to use the document or any part of the document by reproducing, transferring or selling the document. Users should only refer to this document and the content thereof as instructions to operate DJI UAV. The document should not be used for other purposes.

### **Searching for Keywords**

Search for keywords such as “battery” and “install” to find a topic. If you are using Adobe Acrobat Reader to read this document, press Ctrl+F on Windows or Command+F on Mac to begin a search.

### **Navigating to a Topic**

View a complete list of topics in the table of contents. Click on a topic to navigate to that section.

### **Printing this Document**

This document supports high resolution printing.

# Contents

<b>Introduction</b>	<b>5</b>
<b>Disclaimer</b>	<b>5</b>
<b>Safety Guidelines</b>	<b>6</b>
Operational Requirements	6
Firmware Update and System Calibration	6
<b>Recommended Maintenance Interval</b>	<b>7</b>
<b>Maintenance Tool List</b>	<b>8</b>
<b>Dock Maintenance</b>	<b>9</b>
Environment Inspection	9
Dock Body Inspection	9
Electrical Cabinet Inspection	10
Dock Cover Inspection	10
Dock Covers	10
Wind Speed Gauge Module and Rainfall Gauge	11
Landing Pad Inspection	13
Lower Compartment Inspection	14
Lower Compartment Assembly	14
External Circulating Fan	15
Testing the Air Conditioning System	15
External Circulating Air Filters	16
Emergency Stop Button Inspection	17
<b>Aircraft Maintenance</b>	<b>18</b>
Aircraft Body Inspection	18
Aircraft Indicators	18
Propulsion System	19
Frame Arms	19
Motors	20
Propellers and Propeller Adapters	21
Landing Feet	22
Gimbal Camera	22
Infrared Sensing and Vision Systems, Auxiliary Light, and Beacon	23

Aircraft Ports	24
Before Leaving Checklist	26
Intelligent Flight Battery	27
Battery Maintenance	27
Battery Replacement Standard	27
Battery Disposal	27
Battery Usage Warnings	27
<b>List of Wearing Parts</b>	<b>28</b>
Wearing Parts of the Dock	28
Wearing Parts of the Aircraft	28
<b>DJI Maintenance Program</b>	<b>29</b>
Using DJI FlightHub 2	29
Using DJI Pilot 2	30
<b>After-sales Service</b>	<b>32</b>



## Introduction

The Maintenance Manual offers guidelines to help you in the daily upkeep and maintenance of the dock and the aircraft, and also provides after-sales service information.

This document will focus on the maintenance instructions. Read the User Manual and Maintenance Manual carefully to optimize the user experience. If you have any questions on the maintenance operations, contact DJI Support.

## Disclaimer

Carefully read this entire document and all safe and lawful practices provided by DJI™ before using this product for the first time. Failure to read and follow instructions and warnings may result in serious injury to yourself or others, damage to your DJI product, or damage to other objects in the vicinity. By using this product, you hereby signify that you have read this disclaimer carefully and that you understand and agree to abide by all terms and conditions of this document and all relevant documents of this product. You agree to use this product only for purposes that are proper. You agree that you are solely responsible for your own conduct while using this product, and for any consequences thereof. DJI accepts no liability for damage, injury, or any legal responsibility incurred directly or indirectly from the use of this product.

DJI is a trademark of SZ DJI TECHNOLOGY CO., LTD. (abbreviated as “DJI”) and its affiliated companies. Names of products, brands, etc., appearing in this document are trademarks or registered trademarks of their respective owner companies. This product and document are copyrighted by DJI with all rights reserved. No part of this product or document shall be reproduced in any form without the prior written consent or authorization of DJI. This disclaimer is available in various languages. In the event of divergence among different versions, the English version shall prevail. The final interpretation of this document and all related documents of this product belong to DJI. This content is subject to change without prior notice. For up-to-date product information, visit the product page for this product at <http://www.dji.com>.

## Safety Guidelines

Before use, read the Safety Guidelines, User Manual, and Maintenance Manual carefully.

### Operational Requirements

- Make sure to perform the maintenance procedure in accordance with the steps in this manual.
- Measure the voltage on the contact points of the conductors and make sure there is no risk of electric shock before touching any conductor surfaces or terminals. The dock must be powered off before maintenance.
- In order to avoid an electric shock, DO NOT use any tools that are not insulated, such as a screwdriver with a bare metal handle.
- Make sure to wear protective equipment when performing maintenance, such as a safety helmet, goggles, insulated gloves, and insulated shoes.
- Make sure the dock is powered off before checking the movable parts of the dock, such as the fan of the air conditioning system, the dock cover, and the dock cover driving arms to avoid injury.
- Before conducting on-site maintenance, make sure that there is no flight plan to be performed on DJI FlightHub 2 and that the aircraft has landed inside the dock. Make sure to press the emergency stop button on the dock before any operations. When using the DJI RC Pro Enterprise remote controller for on site testing, make sure to connect the remote controller to the dock before releasing the emergency stop button.

### Firmware Update and System Calibration

Update the firmware of the dock, the aircraft, and the Intelligent Flight Batteries to the latest version. If the update fails, restart the device and try again, or use DJI ASSISTANT™ 2 (Enterprise Series) to update the firmware. Contact DJI Support if the issue persists. It is recommended to perform aircraft calibration every six months to keep the aircraft in good condition.

List of Aircraft Calibration:

No.	Tab
1	IMU calibration
2	Compass calibration
3	Gimbal Calibration



- Visit <https://enterprise.dji.com/dock-2/downloads> and refer to the User Manual and Maintenance Manual for more information on aircraft calibration.
- Aircraft calibration can be performed using the DJI Pilot 2. Make sure to link the aircraft to the DJI RC Pro Enterprise remote controller when calibrating the aircraft.

## Recommended Maintenance Interval

It is recommended to perform inspection and maintenance regularly following the listed standards to keep the dock and the aircraft in a good condition and reduce safety risks.

Product	Service Type	Maintenance Items	Maintenance Advice	Maintenance Interval <sup>[1]</sup>
DJI Dock 2	Standard	Deep cleaning, environment inspection, updates and calibrations, and device appearance and parts inspection	Based on actual use or contact a DJI authorized service provider	Per half year <sup>[2]</sup> / Per 1500 flights
	Premium	Standard maintenance items and replacement of wearing parts	Contact a DJI-authorized service provider	Per year <sup>[2]</sup> / Per 3000 flights
Aircraft	Basic	Deep cleaning, parts inspection, updates and calibrations	Recommend factory service or contact a DJI-authorized service provider	Based on actual use. It is recommended to perform basic maintenance for the aircraft when performing standard maintenance for the dock.
	Standard	Deep cleaning, parts inspection, updates and calibrations, and replacement of wearing parts	Recommend factory service	Per 300-hour flights / Per year <sup>[2]</sup> / Per 1000 flights
	Premium	Deep cleaning, parts inspection, updates and calibrations, and replacement of wearing parts and the propulsion system	Recommend factory service	Per 900-hour flights / Per two years <sup>[2]</sup> / Per 3000 flights

[1] The activation time, flight hours, or number of flights specified in the maintenance interval shall be whichever comes first.

[2] Per half year / Per year / Per two years expresses the device activation time.



- DJI Enterprise may adjust the above maintenance services accordingly in different areas. Please contact a DJI-authorized dealer or DJI Support for the latest information.
- If the dock is installed in harsh environments, including but not limited to sandy or dusty environments, environments with a high salinity, high temperature, high humidity, or pollutants nearby, such as chemical plants, lumber mills, sewage treatment plants, or many willow catkins, the maintenance interval should be shortened to 3 months.

## Maintenance Tool List

Adjustable Wrench



Screws and Tools

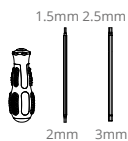

DJI RC Pro Enterprise Remote Controller



USB-C Cable

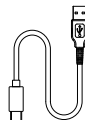

Dust Blower



Soft Brush

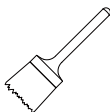

Stiff Brush



Water Container



Dry Cloth



# Dock Maintenance

## Environment Inspection

To ensure flight safety, it is recommended to regularly check the environment near the dock as follows:

1. Clear overgrown plants or animal infestations that can affect normal operation of the dock, such as weeds, trees, ant nests, and rat nests.
2. Check if there are new buildings near the dock that may block the signal. Select another location to install the dock if the signal obstruction becomes strong.
3. Check the ground conditions near the dock, and make sure to clear hidden risks that may cause water immersion or inclination of the dock.
4. Check the environment near the alternate landing site, and clear debris that might affect the aircraft landing.

## Dock Body Inspection

1. Clean the dock shell with a soft, dry cloth and make sure the dock shell is clear of dirt or foreign matter.
2. If there is any noticeable damage or deformation, contact a DJI-authorized service provider in time.
3. Make sure the four expansion bolts are securely mounted. If loosened, tighten the bolts using an adjustable wrench to ensure that the dock is securely installed.

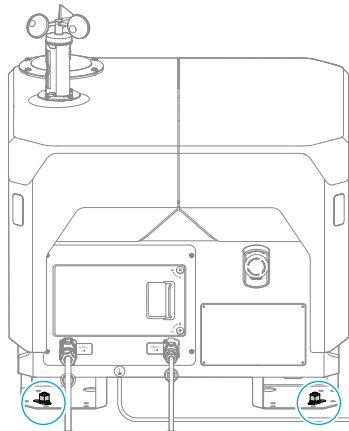

## Electrical Cabinet Inspection

1. Use a 2.5mm hex key to loosen the two screws on the electrical cabinet door.
2. Pull the door to open the electrical cabinet and check the panel.
3. Check the SPD status indicator. Contact a DJI-authorized service provider to replace and repair the SPD if the indicator turns red.
4. Make sure the surge protector circuit breaker (SCB), the AC power switch, and the backup battery switch can be turned on/off normally.

 • Pay attention to safety during operation in order to avoid an electric shock.

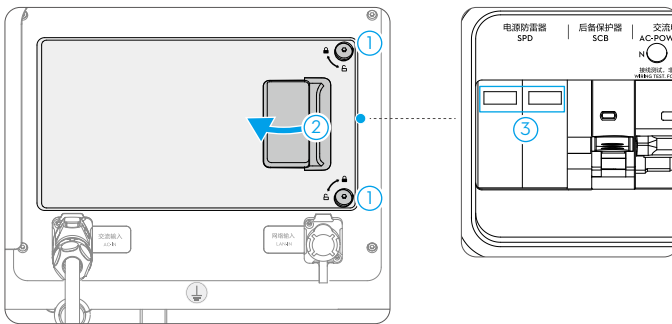

## Dock Cover Inspection

### Dock Covers

1. Power on the dock. Press and hold the open button to open the dock covers. Check if the dock covers can move smoothly without jamming when opening. It is normal for the dock covers to make a sound after extended use, this does not affect normal use.

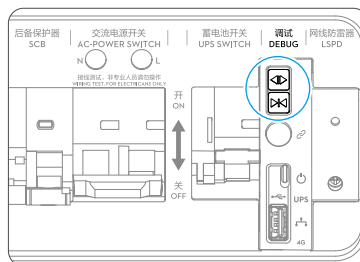

2. Make sure that the dock cover rubber seal strip is in good condition and is securely attached to the dock cover.
3. Make sure that the dock cover propeller bumpers are not damaged or deformed, and the screws are securely mounted.

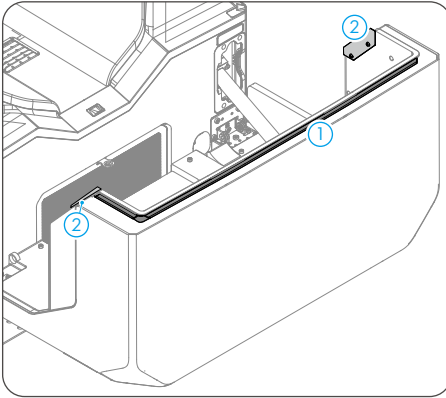

1. Dock Cover Rubber Seal Strip
2. Dock Cover Propeller Bumpers

4. Moisten a soft cloth with clean water or a neutral cleaning solution and clean the dock covers.

- ⚠ • If any of the mentioned parts are broken or damaged, contact a DJI-authorized service provider to replace them.
- The dock cover propeller bumpers are wearing parts. Contact a DJI-authorized service provider and replace them in time when necessary.

## Wind Speed Gauge Module and Rainfall Gauge

1. Make sure the glass of the auxiliary lights and the lenses of the security cameras are clean and not damaged. Moisten a soft cloth with clean water or a neutral cleaning solution to clean the glass and the lens.

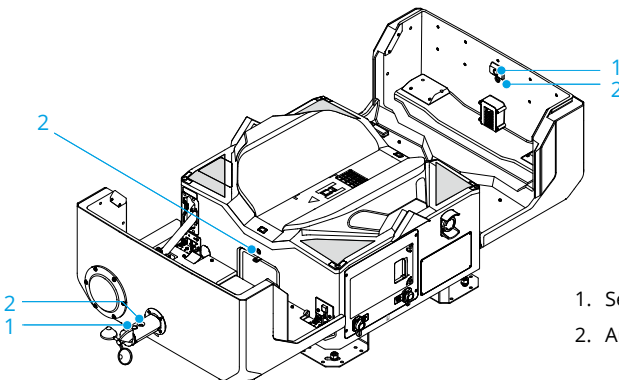

1. Security Camera
2. Auxiliary Light

2. Make sure the wind speed gauge module and the three wind cups are not broken or cracked, and the wind cups can rotate smoothly without damping.
3. Make sure the screws of the wind speed gauge are tightened and the wind speed gauge is securely installed.
4. Make sure the surface of the rainfall gauge is clean and not deformed or damaged. Moisten a soft cloth with clean water or a neutral cleaning solution to clean the surface of the rainfall gauge.

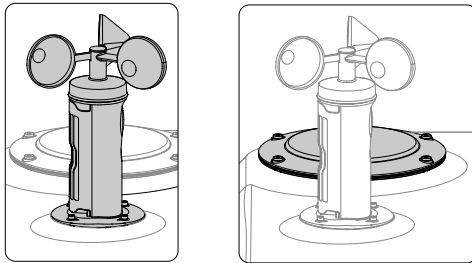

5. Connect the remote controller to the dock, run DJI PILOT™ 2, and enter the Onsite Debugging page.
  - a. Gently rotate the wind cups and check if DJI Pilot 2 displays data.
  - b. Gently tap the surface of the rainfall gauge and check if DJI Pilot 2 displays data.
  - c. Tap Open or Close in the app to test if the dock cover can operate normally.

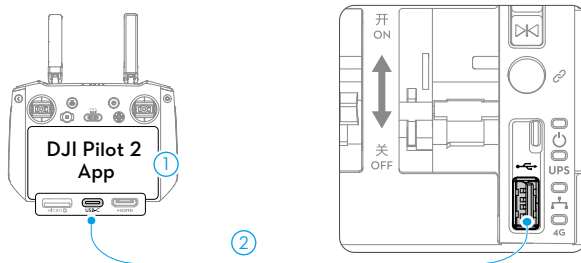

⚠ • If any of the mentioned parts are broken or damaged, contact a DJI-authorized service provider to replace them.



## Landing Pad Inspection

1. Power off the dock, and make sure the landing pad surface, the return vent and the supply vent are not deformed, dented, cracked, or broken.
2. Make sure the Aircraft Orientation Marker (H) and the Positioning Markers are clear and not worn.

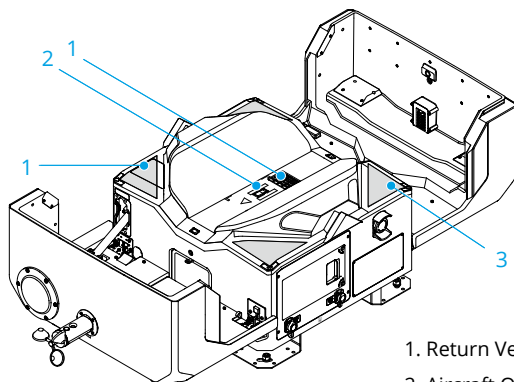

1. Return Vent and Supply Vent
2. Aircraft Orientation Marker
3. Positioning Markers

3. Make sure the six water-resistant rubber covers are not loose or damaged.

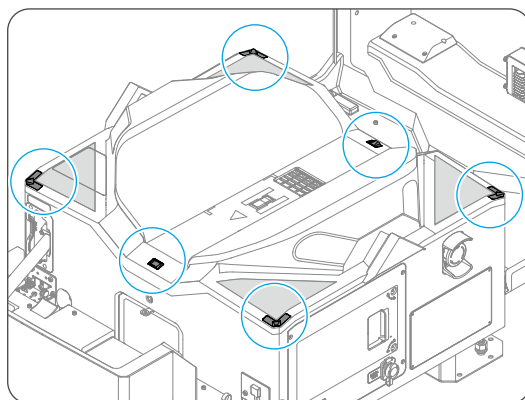

4. Moisten a soft cloth with water or a neutral cleaning solution to clean the landing pad surface and the vents, and make sure the return vent and the supply vent are clear of foreign matter.

 • If any of the mentioned parts are broken or damaged, contact a DJI-authorized service provider to replace them.

## Lower Compartment Inspection

1. Power on the dock. Press and hold the open button to open the dock covers.
2. Turn off the backup battery switch and the AC power switch to power off the dock, and close the electrical cabinet door.
3. Remove the six water-resistant rubber covers on the landing pad and loosen the landing pad screws using a 2.5mm hex key.
4. Remove the landing pad to open the lower compartment.

## Lower Compartment Assembly

1. Make sure the return vent, the supply vent, and the heating module on the surface of the return vents are clean and not damaged.
2. Make sure the built-in charging module and the cables are not broken or cracked.
3. Make sure the dock cover driving arms are secure and stable.
4. Clean any stagnant water in the lower compartment. A small amount of stagnant water does not affect the normal operation. If a water immersion warning appears in DJI FlightHub 2, contact a qualified electrician to disconnect the dock power supply and remove the water.
5. Moisten a soft cloth and a soft brush with water or a neutral cleaning solution to clean the parts in the lower compartment. Remove the dust using the dust blower. Take care to avoid pulling the cables when cleaning the lower compartment.
6. Make sure that there is no foreign matter in the lower compartment.

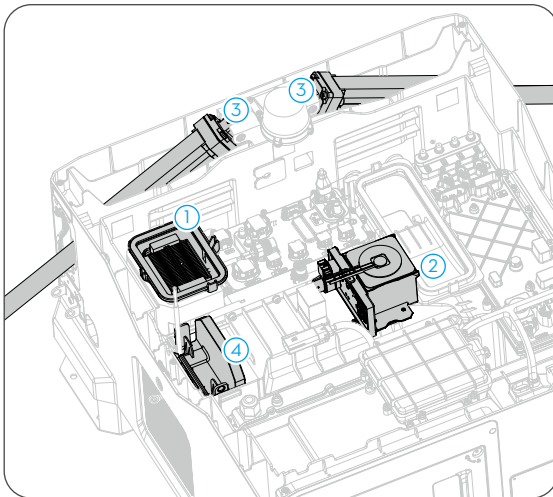

1. Return Vent and the Heating Module
2. Built-in Charging Module

3. Dock Cover Driving Arms
4. External Circulating Fan

## External Circulating Fan

- 
-  • Make sure that the dock is powered off and the external circulating fan stops spinning before operation.
- 

1. Take photos to record the wiring status of the external circulating fan.
2. Press and hold the buckles to lift the fan.
3. Check the fan blades and make sure they are not broken. Gently rotate the blades with a screwdriver to check if the blades can rotate smoothly.
4. Clean the fan using the soft brush and the dust blower.
5. After completing inspection and cleaning, press and hold the buckles and insert the fan. Make sure the fan is inserted with a clicking sound, which indicates the fan is securely installed.
6. Organize the cables near the fan to avoid damaging the cables.

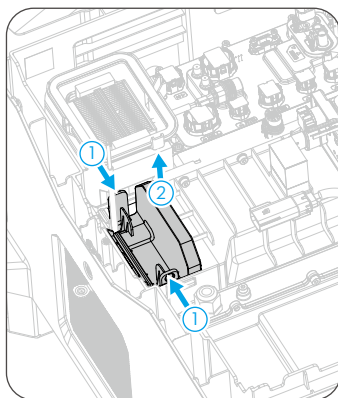

## Testing the Air Conditioning System

1. Re-install the landing pad after completing inspection and cleaning.
2. Mount the landing pad screws using a 2.5mm hex key and re-insert the water-resistant rubber covers. Make sure the rubber covers are firmly closed.
3. Power on the dock and connect the remote controller to the dock. Run DJI Pilot 2 and enter Dock Onsite Debugging page, and tap Cooling or Heating. Check if there is cool air or hot air from the supply vent to test the air conditioning system.

- 
-  • To ensure the service life of the air conditioning system, a five-minute interval is required when switching between cooling and heating operations. A countdown will appear in the app. Wait for the countdown to end before switching operations.
-

## External Circulating Air Filters

1. Power on the dock. Press and hold the open button to open the dock covers.
2. Press and hold the buckle and pull out to remove the air filter.
3. Clean the air filter using a stiff brush.
4. Repeat step 1-3 to remove and clean the air filter on the other side.
5. After cleaning, mount the air filter to the bottom of the outer frame, push inward until a clicking sound is heard, this indicates that the air filter is mounted in place.

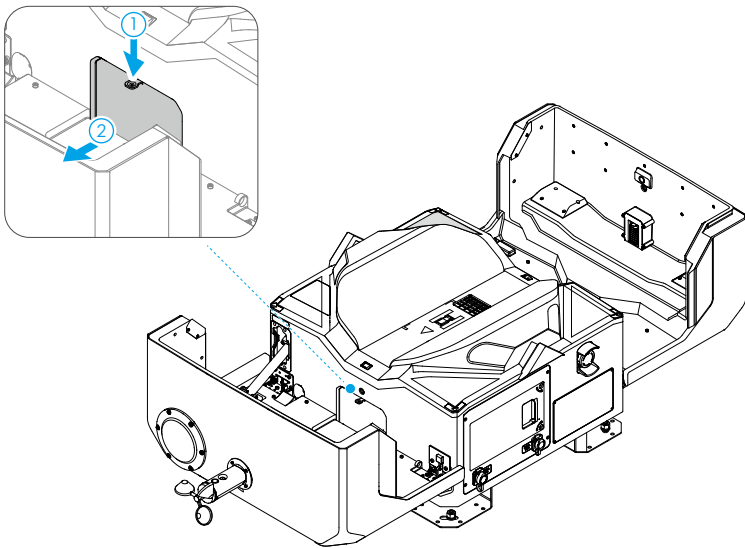

## Emergency Stop Button Inspection

Make sure the emergency stop button can be pressed and released without jamming. The Status Indicators blink red and yellow alternatively after pressing the emergency stop button.

Pull out or rotate clockwise to release the emergency stop button after inspection.

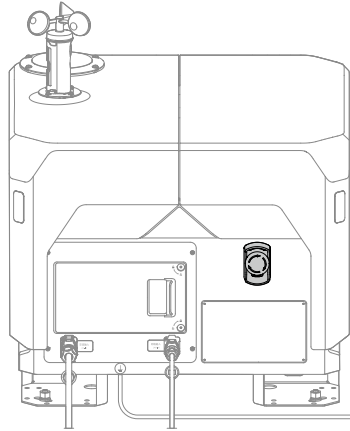

# Aircraft Maintenance

## Aircraft Body Inspection

1. Make sure the aircraft body is clean and not damaged.
2. Clean the aircraft body with a dry, soft cloth paying special attention to the lenses of the infrared sensing and vision systems and the heat dissipation vents.

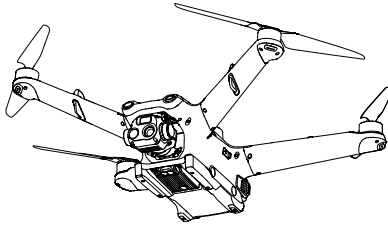

## Aircraft Indicators

Make sure the front LEDs and the aircraft status indicators are clean and not damaged.

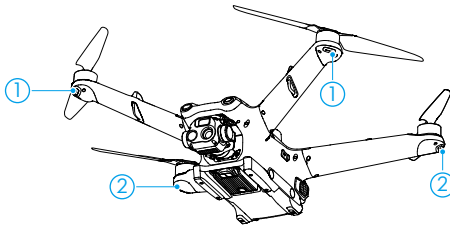

1. Aircraft Front LEDs
2. Aircraft Status Indicators

## Propulsion System

### Frame Arms

1. Make sure the connecting screws of the frame arms and the aircraft body are firmly tightened.
2. Make sure the antennas on the frame arms are not damaged.
3. Make sure the frame arms are not cracked or damaged.

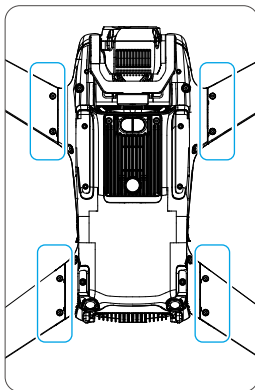

4. Make sure the two mounting screws at the end of the frame arms are not loose. If any screws are loose, return the aircraft to the factory for repair.

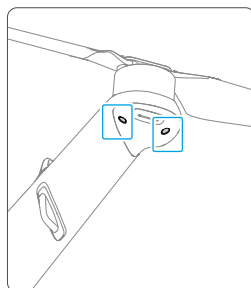

## Motors

### Motor Rotation

1. Rotate the propeller motors to check if the propellers are jammed or make any abnormal sounds, and whether the rotor and stator of the motors scratch the motor base.
2. DO NOT fly the aircraft if the propellers are jammed or make any abnormal sounds. If there are any abnormalities, make sure to return the aircraft to the factory for repair.

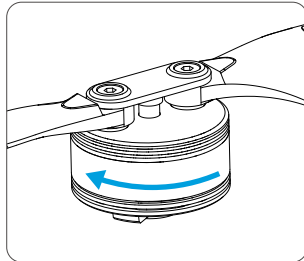

### Motor Air Filters

1. Make sure the air filters are not severely damaged or deformed.
2. If they are severely damaged or deformed (such as being bumped), return the aircraft to the factory for repair.

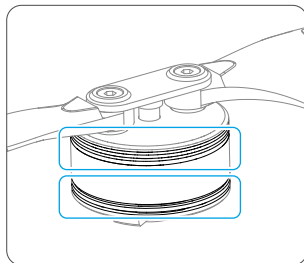



## Propellers and Propeller Adapters

### Propellers

1. Check the propellers for visible deformation, severe wear, nicks, and cracks, and if there is any foreign matter on the propellers.
2. Clean the propellers with a dry, soft cloth.
3. Replace the propellers immediately if there are any visible deformations, nicks, cracks, or severe wearing occurs.<sup>[1]</sup>
4. The propellers are wearing parts. Replace the propellers, washers, and screws in time when necessary.<sup>[1]</sup>

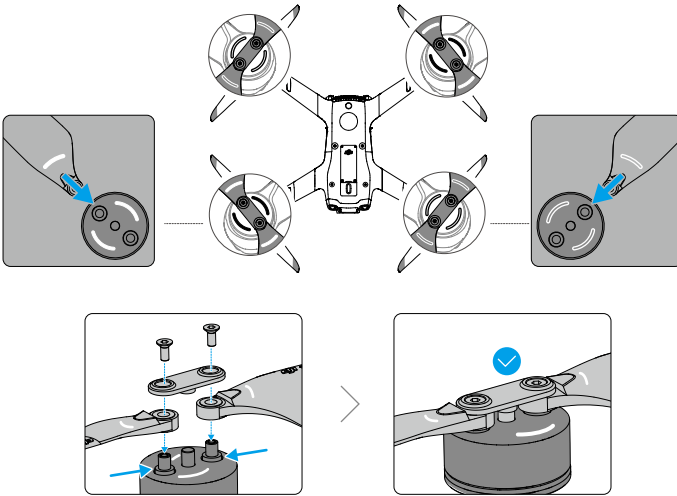

### Propeller Adapters

1. Make sure the propeller adapter screws are securely tightened.
2. If the screws are loose, apply screw glue and tighten the screws.
3. Make sure the propeller adapters are not damaged or deformed.
4. Replace the propeller adapters if they are damaged or deformed.

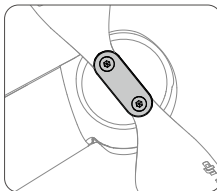

[1] The propellers need to be replaced in pairs. Make sure to use screw glue (recommended model: 243) when replacing the propellers. It is recommended to contact a DJI-authorized service provider for propeller replacement.

## Landing Feet

Make sure the landing feet are not cracked or damaged, and the landing feet pads are not worn.

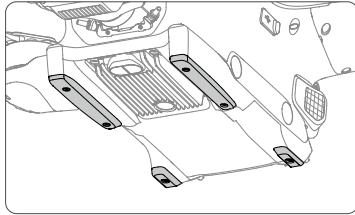

## Gimbal Camera

### Gimbal Damping Plate

1. Make sure the gimbal dampers are not damaged, loose, aged, or deformed.
2. Make sure the screws connecting the damping plate and aircraft body are firmly secured.
3. The gimbal dampers are wearing parts. Return the aircraft to the factory and replace them when necessary.

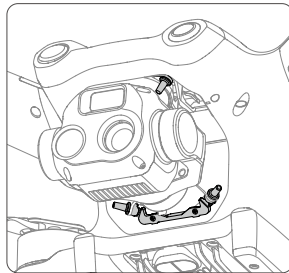

### Gimbal Camera

Make sure the lenses on the camera are not damaged or cracked.

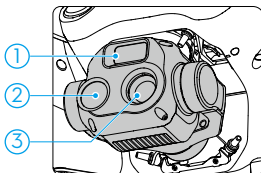

Matrice 3TD

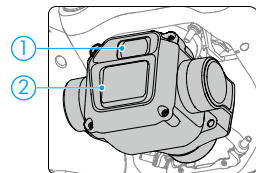

Matrice 3D

1. Tele camera
2. Wide Camera
3. Infrared Camera

## Infrared Sensing and Vision Systems, Auxiliary Light, and Beacon

1. Clean the lenses with a soft, dry cloth.
2. Make sure the lenses are not loose or cracked.
3. Make sure the auxiliary light and beacon are not loose or cracked.

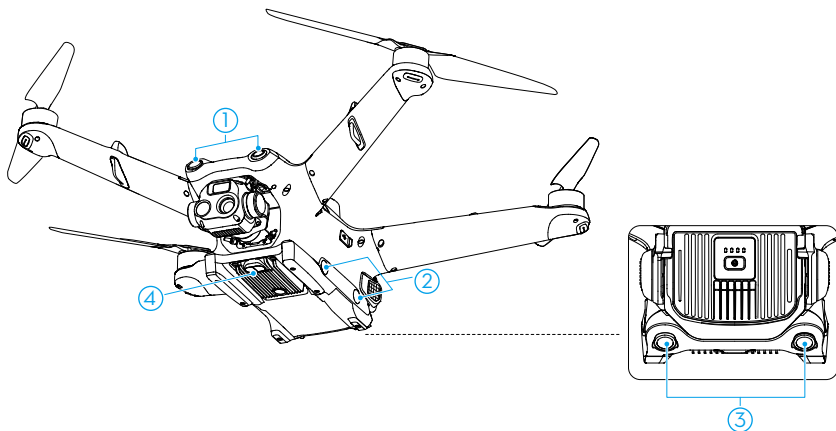

Infrared Sensing and Vision Systems

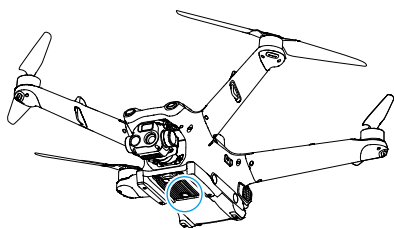

Auxiliary Light

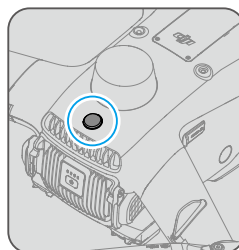

Beacon

## Aircraft Ports

### Battery Compartment

1. Check if the battery port is clean and dry without any corrosion. Clean any unwanted dust or water inside the battery compartment.
2. Make sure the battery can be firmly installed without shaking.

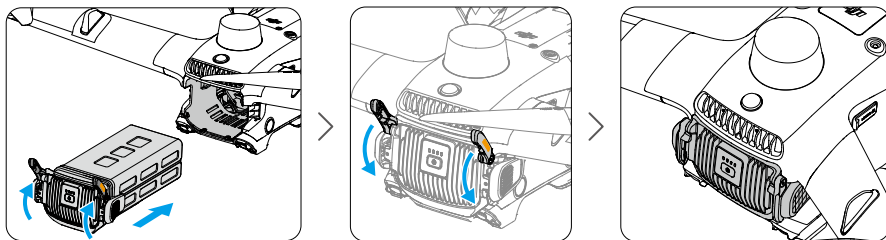

### Data Ports

1. Clean any unwanted residue near the ports with a soft, dry cloth.
2. If the ports are in use, disconnect the cables, and check if there is any unwanted residue in the ports using a torch.
3. Place the aircraft at an angle and use a dust blower and a soft brush to remove any small matter, such as dust from the port. Make sure to clean thoroughly, sweeping away from the port.
4. If a third-party payload is used, make sure the waterproof rubber ring of the cable connector is in good condition to ensure that the port is well sealed.
5. Return the aircraft to the factory for repair if there is any water immersion marks on the ports.

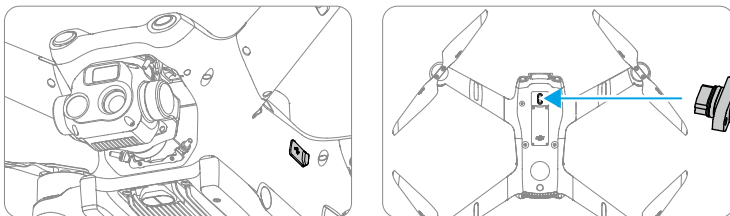

## Rubber Port Covers

Make sure the rubber port covers are not damaged or loose, and are properly sealed.

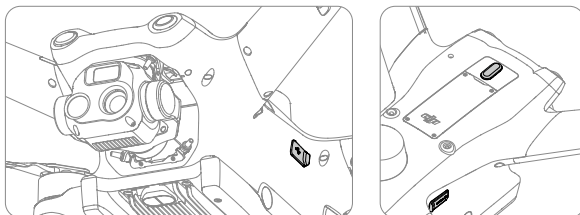

## microSD Card Slot

1. Check if there are any foreign matter in the microSD card slot, and if the microSD card can be correctly installed and removed.
2. Check if the microSD card is working properly.

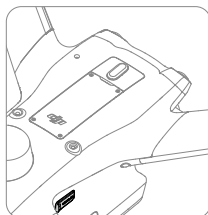

## Heat Dissipation Vents

Make sure that there is no blockage in the heat dissipation vents and the cooling fans work normally without any abnormal noise.

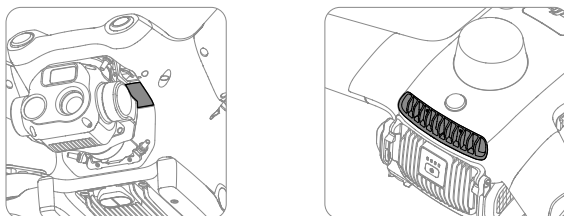

## Before Leaving Checklist

After completing maintenance for the dock and the aircraft, make sure to check the following items before leaving the site:

1. Place the aircraft on the landing pad and make sure the aircraft heading is aligned with the arrow mark.
2. Make sure the water-resistant rubber port covers are correctly in place and securely sealed.
3. Make sure to close the dock cover and the electrical cabinet door.
4. Pull out the emergency stop button on the dock and make sure it is released.
5. Perform the automatic operation test to ensure that the dock and the aircraft can operate normally. Refer to the Installation and Setup Manual for more information.

## Intelligent Flight Battery

### Battery Maintenance

The Intelligent Flight Battery will perform a self-evaluation and the dock will automatically maintain the battery to ensure optimal battery performance. If a warning message appears in DJI FlightHub 2, click the message to view warning details, and follow the instructions to perform battery maintenance.

When the battery life is approaching, a prompt will appear in DJI FlightHub 2. If users continue to use the battery, the dock cannot perform flight tasks when the battery life is reached.

### Battery Replacement Standard

1. The battery is visibly swollen, leaky, or damaged.
2. Batteries are rated for 400 cycles. The stability of a battery will be affected after the rated cycles are complete. In this case, make sure to replace the battery. Otherwise, users are responsible for device damage and third-party losses caused by batteries exceeding the rated cycles.
3. The battery error still exists after performing the standard charge and discharge operations twice continuously.

### Battery Disposal

1. Remove the protective plastic sheet on the battery. Fully immerse the battery in an insulated bucket with 5% salt solution and leave the battery in the solution for more than 48 hours to fully discharge the battery.
2. It is recommended to recycle the battery following the instructions in Safety Guidelines to avoid environmental pollution.

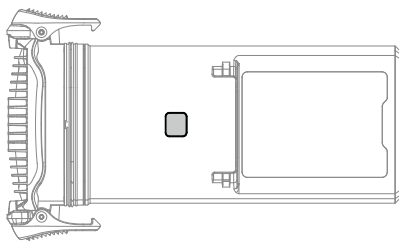

### Battery Usage Warnings

1. DO NOT charge the battery near flammable materials and objects or on flammable surfaces.
2. DO NOT use the battery in a humid environment to avoid short circuit.
3. DO NOT disassemble or pierce the battery in any way.
4. Store the battery in a well-ventilated and dry place.
5. Initiate RTH immediately when DJI FlightHub 2 prompts that the battery temperature is too high.

## List of Wearing Parts

Replace parts that are easily damaged and worn in time to keep the dock and the aircraft in good condition and reduce flight safety risks.

### Wearing Parts of the Dock

Wearing Part	Quantity	Replacement Interval - Based on Activation Time <sup>[1]</sup>	Replacement Interval - Based on Total Flights <sup>[1]</sup>
Dock Cover Rubber Seal Strip	1	Per 12 months	/
Propeller Bumpers	4	Per 12 months	Per 3000 flights
Backup Battery	1	Per 24 months	/
Dock Cover Driving Arms	1	Per 36 months	Per 5000 flights
External Circulating Fan	1	Per 36 months	/

[1] The activation time or total flights specified shall be whichever comes first.

### Wearing Parts of the Aircraft

Wearing Part	Quantity	Replacement Interval - Based on Activation Time <sup>[1]</sup>	Replacement Interval - Based on Total Flight Time <sup>[1]</sup>	Replacement Interval - Based on Total Flights <sup>[1]</sup>
CW Propeller Blades <sup>[2]</sup>	4	Per 12 months	Per 300-hour flights	Per 1000 flights
CCW Propeller Blades <sup>[2]</sup>	4	Per 12 months	Per 300-hour flights	Per 1000 flights
Gimbal Dampers	4	Per 12 months	Per 300-hour flights	Per 1000 flights
Motors <sup>[3]</sup>	4	Per 24 months	Per 900-hour flights	Per 3000 flights
Aircraft Frame <sup>[3]</sup>	1	Per 24 months	Per 900-hour flights	Per 3000 flights
Frame Arms <sup>[3]</sup>	4	Per 24 months	Per 900-hour flights	Per 3000 flights
Landing Feet	4	During standard maintenance, replace the landing feet if they are cracked or severely worn.		

[1] The flight time, activation time, or total flights specified shall be whichever comes first.

[2] Each motor is used with two CW propeller blades or two CCW propeller blades.

[3] Replace only for premium maintenance.



# DJI Maintenance Program

## Using DJI FlightHub 2

1. Open DJI FlightHub 2, click Devices > Dock > , and enable Remote Debugging.

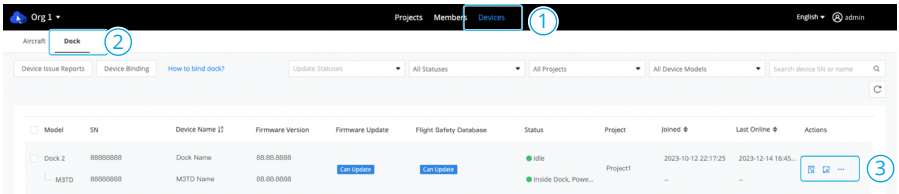

2. Click DJI Maintenance Program to view device data, maintenance records, and maintenance details of the dock and the aircraft.

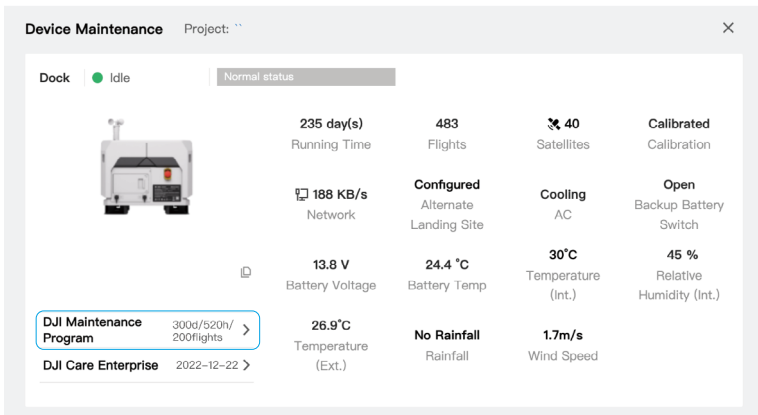

3. Users can purchase the DJI Maintenance Program or request maintenance on this page.

-  • Contact a DJI-authorized service provider for dock maintenance. Submit an online repair request for aircraft maintenance.
- When the maintenance interval is approaching or is due, DJI FlightHub 2 will highlight the corresponding maintenance in orange (standard maintenance) or red (premium maintenance).

## Using DJI Pilot 2

1. Connect the remote controller to the dock to enter the Onsite Debugging page.

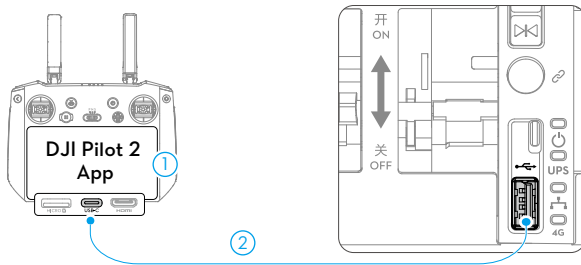

2. Tap DJI Maintenance Program to view device data, maintenance records, and maintenance details of the dock and the aircraft to help users determine if maintenance is required.

### Dock Onsite Debugging

Place aircraft inside dock and close dock cover after debugging. Distribute task in DJI FlightHub 2 or through third-party



**DJI Dock Test** >

Dock No.1

NFZ >

**DJI Maintenance Program** >

DJI Care Enterprise >

**Dock** Nomal >

Running time	Flights	AC	Battery Switch
<b>77 days</b>	<b>3</b>	<b>Idle</b>	<b>On</b>
Battery Volt	Battery Temp	Int. Temp	Int. RH
<b>24.9V</b>	<b>25.0°C</b>	<b>28.1°C</b>	<b>18%</b>
Ext. Temp	Rainfall Scale	Wind Speed	
<b>28.1°C</b>	<b>No Rainfall</b>	<b>2m/s</b>	

Network  
57K/s

Dock Location  
Null

Alternate landing site  
 Set

**Aircraft**

Batteries      Battery

- After completing standard maintenance for the dock, connect the DJI RC Pro Enterprise remote controller to the dock and reset the standard maintenance count. Tap Reset Standard Service Count to reset the standard maintenance count.

<
DJI Maintenance Program
DJI Care Enterpris

---

**Dock Data**

Running Time  
**814 h**

Flights  
**500**

Activation Date  
**2019-12-12**

SN: R0AIE03350459035

---

**Details**

[Maintenance Rules >](#)

Maintain dock regularly based on maintenance rules for enhanced safety

Last Maintenance

<b>Details</b>	Standard service
<b>Date</b>	2022-10-10
<b>Flights</b>	300 flights

Next Maintenance

<b>Standard Service</b>	24 days /520 flights
<b>Premium Service</b>	4 days/140 flights

The above maintenance schedule is for reference only. Schedule maintenance services based on maintenance records on the official DJI website

Reset Standard Service Count

- When the standard maintenance interval is approaching or is due, the text color will be highlighted in orange.

<b>Type</b>	Basic Service	Based on actual use
Total Flight Duration	Standard Service	12h/365d
Date	Premium Service	612h/1095d

The above maintenance schedule is for reference only. Schedule maintenance services for your DJI devices based on their maintenance records on the official DJI website.

- When the premium maintenance interval is approaching or is due, the text color will be highlighted in red.

<b>Type</b>	Basic Service	Based on actual use
Total Flight Duration	Standard Service	900h overdue
Date	Premium Service	300h overdue

The above maintenance schedule is for reference only. Schedule maintenance services for your DJI devices based on their maintenance records on the official DJI website.

## After-sales Service

Visit <https://www.dji.com/service/policy> to view product warranty period and warranty policy.

WE ARE HERE FOR YOU



Contact  
DJI SUPPORT

This content is subject to change without prior notice.  
Download the latest version from



<https://enterprise.dji.com/dock-2/downloads>

If you have any questions about this document, contact  
DJI by sending a message to [DocSupport@dji.com](mailto:DocSupport@dji.com).

DJI and MATRICE are trademarks of DJI.  
Copyright © 2024 DJI All Rights Reserved.