

N3

User Manual V1.4

2017.04

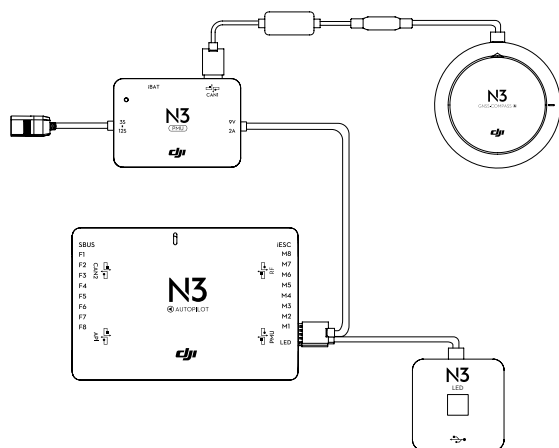

Searching for Keywords

Search for keywords such as “battery” and “install” to find a topic. If you are using Adobe Acrobat Reader to read this document, press Ctrl+F on Windows or Command+F on Mac to begin a search.

Navigating to a Topic

View a complete list of topics in the table of contents. Click on a topic to navigate to that section.

Printing this Document

This document supports high resolution printing.

Using this manual

Legends

 Warning

 Important

 Hints and Tips

 Reference

Before Flight

The following tutorials and manuals have been produced to ensure you to make full use of your N3.

1. In the Box
2. Safety Guidelines and Disclaimer
3. Quick Start Guide
4. User Manual

Make sure all of the parts listed in the In the Box document are included in the package.

The information in the Safety Guidelines and Disclaimer document affects your safety and your legal rights and responsibilities. Read this entire document carefully to ensure proper configuration before use.

Follow the Quick Start Guide step by step to setup and use the N3 correctly by referring to the User Manual and using the DJI Assistant 2.

The N3 is a powerful systems. To make use of all their capabilities, read the user manual thoroughly before configuring the device.

Contents

Using this manual	
Legends	2
Before Flight	2
Product Profile	4
Introduction	4
System Components	4
Installation	7
Overview	7
Preparation	8
Start the Installation	11
N3 Functions	19
Compass Calibration	19
Flight Functions	20
Protection Functions	23
Flight Limits and Flight Restriction Areas	25
Using with DJI GO app	29
Triple Modular Redundancy	32
SDK	33
Flight Control System Checklist	33
Hardware Checklist	33
DJI Assistant 2 Checklist	33
Flight Safety	34
Appendix	34
LED Indicators	34
Troubleshooting	35
Specifications	36

Product Profile

Introduction

The N3 is a third generation NAZA™ flight control system designed for serious multi-rotor enthusiasts. It is a reliable and robust system with double IMUs and can be expanded with external high-performance sensors. It uses advanced control algorithms and sensor fusion algorithms to maintain complete stability and integrity of the aerial system.

The N3 is fully compatible with the DJI™ Onboard and Mobile SDKs and other DJI products, allowing developers to optimize the system for specific applications. When used with DJI Lightbridge 2, it provides direct access to DJI GO features including Intelligent Flight Modes.

With all essential components integrated into the N3 flight controller (including double IMUs, barometer and data recorder), the device is powerful and highly compact to work together with the GNSS-Compass module (including GPS and GLONASS), PMU module and LED module.

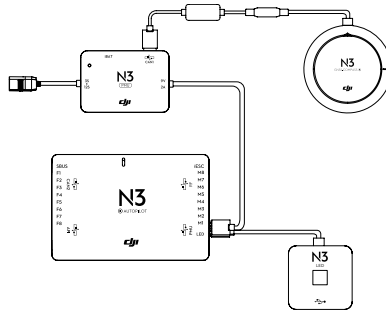

System Components

How the System Works

The flight controller is the core module of the N3 flight control system, which utilizes the IMU, barometer, GNSS and compass to realize accurate attitude control and high-precision positioning for the aircraft. Multiple interfaces for SDK development and DJI devices, such as the Zenmuse Z15 gimbals, are also provided. The DJI Assistant 2 software allows you to configure parameters for installation, flight control, and other accessed devices. A simulator is also available for simulated flight practice. When used with the DJI Lightbridge 2, the N3 has direct access to features in the DJI GO app such as Intelligent Flight Modes.

N3 and N3 Pro Parts

Flight Controller

Feature Highlights

1. Independent CAN1 and CAN2 ports and API Serial port for the Onboard SDK. The CAN1 port is used to connect the GNSS-Compass and DJI devices while the CAN2 port is used to connect SDK devices.
2. Built-in inertial sensors for the measurement of aircraft attitude and built-in pressure sensor for the detection of aircraft altitude.
3. Support for multiple receiver types. If used with the DJI Lightbridge 2, the N3 has direct access to features in the DJI GO app such as Intelligent Flight Modes.
4. M1 to M8 are used to connect the ESCs of the aircraft and iESC for DJI Intelligent ESC communication.
5. 4 independent and configurable output ports and 4 I/O ports. These ports can be customized and connect other DJI devices (e.g. DJI Zenmuse Z15 gimbals, DJI Intelligent Landing Gear) or SDK devices.

Port Diagram

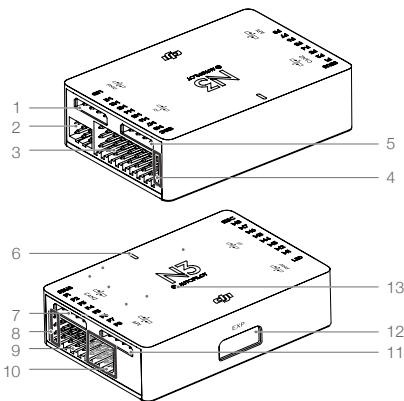

Flight Controller

1. PMU Port
Derives power from the PMU module.
2. LED Port
Communicates with the LED module.
3. M1-M8 Pins
Connects to the corresponding ESC PWM port for each motor.
4. iESC Port
Communicates with the DJI Smart ESC using the Smart ESC Communication Cable.
5. RF Port
Communicates with the DJI Lightbridge 2 Air System.
6. Status Indicator
Indicates the status of the flight controller.
7. CAN2 Port
CAN Bus port (Reserved port).
8. S-Bus Port
Communicates with a DJI DR16 or S-Bus receiver.
9. F1-F4 Pins
Multifunction PWM output ports.
10. F5-F8 Pins
Multifunction PWM I / O ports.
11. API Port
Communicates with an Onboard SDK device.
12. EXP Port
Extended port (Communicates with the A3 upgrade kit).
13. Orientation Arrow
The flight controller orientation arrow.

GNSS-Compass Module

The GNSS-Compass module has a built-in GPS/GLONASS and compass. The compass is used for geomagnetic field measurements. Compass calibration is required before use. DO NOT use or store the compass in environments with ferromagnetic materials.

1. Orientation Arrow

The GNSS-Compass module should be mounted with the arrow pointing toward the aircraft nose.

2. GNSS-Compass Status Indicator

Indicates the status of the GNSS-Compass Module.

3. Extended CAN1 Port

Dedicated DJI CAN-Bus port. Communicates with a DJI device.

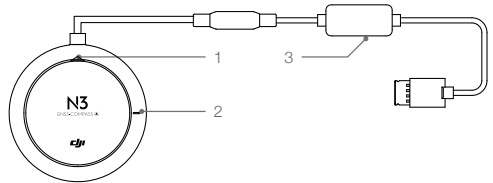

PMU Module

Supported the LiPo batteries, with built-in PMU providing power for the whole Flight Control System and low voltage protection function.

1. iBAT

Reserved.

2. Power Status Indicator

Indicates the power status of the flight control system.

3. 3S-12S

Derives power from LiPo battery.

4. Power Port (9V 2A)

Connected to the Flight Controller for power supply.

5. CAN1 Port

Connected to the GNSS-Compass module.

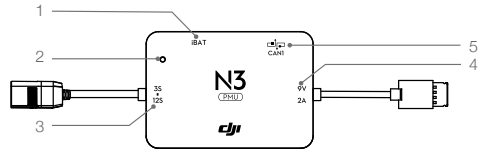

LED Module

The LED Module has an integrated LED Indicator and Micro USB port.

- A. The LED is mainly for flight control system status indication during flight (e.g. Flight Mode).
- B. In addition, there is a Micro USB port for firmware upgrades via DJI Assistant 2.

1. Flight Status Indicator

Indicates the status of the flight control system.

2. Micro USB Port

Used to configure and upgrade the N3 via DJI Assistant 2.

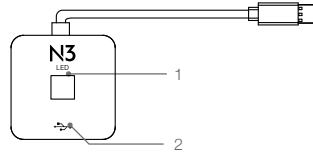

Installation

Overview

Installation Procedure

Read this section carefully and follow the procedures below to install your flight control system, otherwise the flight control system may not normally work.

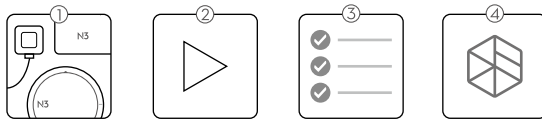

- ① Ensure all parts are in good condition.
- ② Watch video tutorials (<http://www.dji.com/n3>):
 - Watch the installation and connection video tutorials for an overview of the installation process. Then mount the parts to your airframe and connect them properly.
 - Watch the DJI Assistant 2 video tutorial for a brief introduction on how to configure the parameters. Then launch the DJI Assistant 2 and configure the parameters.
- ③ Ensure the motor, remote controller channels and Failsafe settings are correct.
- ④ Ensure the devices connected to the flight controller are working normally and correctly set in DJI Assistant 2.

The following diagram shows a completed installation for the S900 (with the A3 Upgrade Kit.).

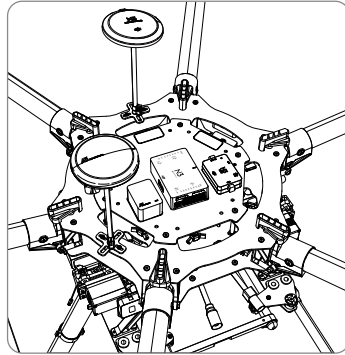

Preparation

Equipment

Ensure you have a suitable airframe, remote controller system, ESCs and battery to use with the N3. You can also prepare optional equipment, e.g. DJI Intelligent Landing Gear, DJI Zenmuse Z15 series gimbals, Below is a list of compatible equipment.

A. Airframes

The following airframes are supported. Choose an airframe and assemble it properly. Remember to select the corresponding airframe type in DJI Assistant 2 after assembling the airframe and connecting the cables.

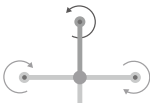

I4



X4

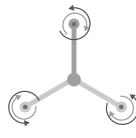

IY6

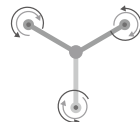

Y6

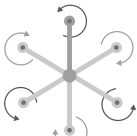

I6

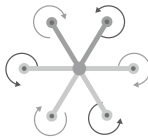

V6

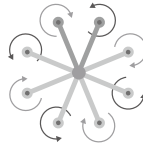

V8

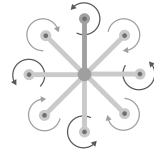

I8

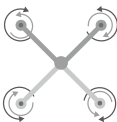

X8

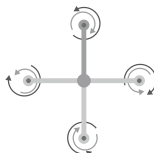

IX8



- The arrow directions in the above diagram indicate the rotation direction of the motor/propeller. Dark colored arm (s) indicate the direction of the aircraft's nose.
 - For coaxial propellers, dark colored propellers are at the top and gray colored propellers are at the bottom. Otherwise, all propellers are at the top.
-

B. Remote Controller System

The following remote controller systems are supported. Whatever type of receiver is used, please make sure that the receiver and remote controller are linked properly before use. Be sure to link the receiver and remote controller according by following all the procedures in the remote controller and receiver user manual, and according to the configurations in DJI Assistant 2.

DJI Lightbridge 2

DJI Lightbridge 2 lets you use DJI GO to configure the flight control system parameters and utilize Intelligent Flight Modes.

DR16

The DR16 receiver does not support the Point of Interest (POI) and Waypoint flight modes in DJI GO app.

S-Bus

The S-BUS receiver does not support the Point of Interest (POI) and Waypoint flight modes DJI GO app.



There is no need to enable the Failsafe function on the remote controller. Once the receiver loses signal from the remote controller, the controller unit will enter Failsafe mode automatically, and the aircraft will hover or return-to-home & land according to the Failsafe configurations in DJI Assistant 2.

C. Propulsion System

ESC

ESC output should be 400Hz. DJI Propulsion systems are recommended.

The iESC port can connect to the DJI Smart ESC Communication Cable if using the DJI Intelligent ESC.

Propeller and Motor

It is required to use with Propeller and Motor of more than 2400rpm.

D. Battery

If using a LiPo battery, only the voltage information and low voltage protection are available.

The S900 and DJI Lightbridge 2 are recommended for the N3 series, and are used as examples in this manual.

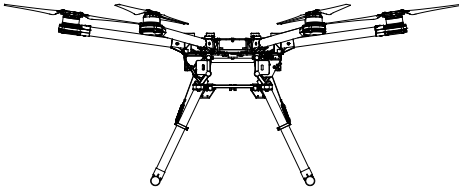

DJI S900

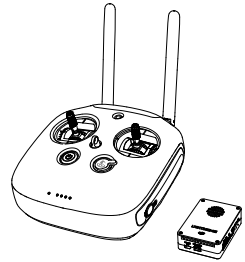

DJI Lightbridge 2

Preparing DJI Assistant 2

Download DJI Assistant 2

DJI Assistant 2 is used to configure the flight control system.

<http://www.dji.com/n3/info#downloads>

 Supports Windows 7 (or later) or Mac OS X 10.9 (or later).

Installing DJI Assistant 2

DJI Assistant 2 will guide you through setting the Flight Control System's parameters. Carefully follow the on-screen prompts to configure the Flight Control System.

Installing and Running on Windows

Supports Windows 7, Windows 8, Windows 10 (32 or 64 bit).

1. Connect the Micro USB port on the LED module to a PC via a Micro USB cable.
2. Run the software assistant installer and follow the prompts to finish installation.
3. Double click the software assistant icon on your Windows desktop to launch the software.

Installing and Running on Mac OS X

Supports Mac OS X 10.9 (or later).

1. Run the DMG installer and follow the prompts to finish installation.
2. If using Launchpad to run DJI Assistant 2 for the first time, Launchpad will not allow access because the software has not been reviewed by the Mac App Store.
3. Locate the DJI Assistant 2 icon in the Finder, press the Control key and then click the DJI Assistant 2 icon (or right-click the DJI Assistant 2 icon using a mouse). Choose Open from the shortcut menu, click Open in the dialog box and the software will launch.
4. After the first successful launch, direct launching of the software can be achieved by double-clicking the DJI Assistant 2 icon in the Finder or using Launchpad.

- DJI Assistant 2 works exactly the same way on Mac OS X and Windows. The DJI Assistant 2 screenshots that appear in this manual are taken from the Windows version.
- ⚠ • For safety reasons, do not use the power battery for power supply or remove the propellers from the motors before connecting to the Assistant Software. he Windows version.

Start the Installation

Important: Strictly follow the provided guidelines. Failure to do so may lead to unexpected flight behavior or serious accidents.

Flight Controller System Installation

Mounting the Flight Controller

Mount the Flight Controller with the Orientation Arrow pointing to the front, back, left or right. Make sure the module is parallel to the aircraft and then fix it onto the aircraft with double-faced adhesive tape. Configure the parameters in DJI Assistant 2 and select the direction in which you mounted the Flight Controller. We recommend mounting the Flight Controller with the Orientation Arrow pointing forward.

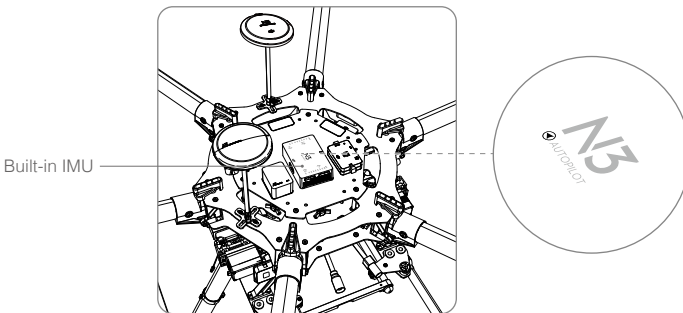

- ⚠ • The top side should be facing up. DO NOT mount upside-down.
- ☀ • Remember to warm up the battery if operating in cold weather.
- ☀ • Mount the flight controller at a low vibration position. The sides of the flight controller should be precisely parallel to the aircraft body. Based on our experience, there is less vibration near the aircraft's center of gravity.
- The flight controller is NOT water-proof or oil-proof.
- Check the double-faced adhesive tape regularly to ensure the IMU is fixed firmly in place.

Mounting the GNSS-Compass Module

Follow the procedures below to mount the GNSS-Compass bracket and the GNSS-Compass module. The GNSS-Compass module included in the Upgrade kits is the same as the one in the N3 package.

1. Use the M2.0×4 screws to assemble the GNSS-Compass bracket with the Ball End Hex Key assistant. The longest one is recommended.
2. With the M2.5×7 screws and M2.5×3.4 nuts, mount the bracket on the aircraft.

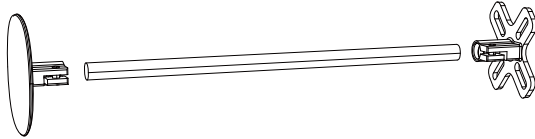

3. Ensure the GNSS-Compass arrow is pointing to the aircraft nose and then fix it onto the top of the GNSS-Compass bracket. Try to keep it parallel to the aircraft.

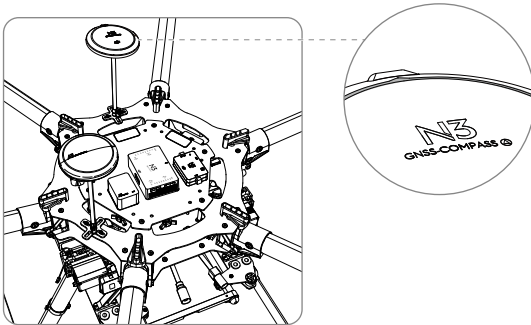

Usage Requirements

1. The DJI logo should be facing the sky, with the orientation arrow pointing directly to the nose direction; otherwise you may experience take off failure.
2. Fly the aircraft in an open space without buildings or trees; otherwise the GPS satellite number may be affected.
3. The compass is sensitive to magnetic interference. Always keep the compass module away from magnetic fields. Otherwise, the compass module may become damaged and lead the aircraft to work abnormally or even lose control.
4. Select a bracket of appropriate length for you aircraft to avoid interference with the compass. The length is based on the airframe type and the mounting position and so on. Ensure that there will not any compass warning when the aircraft is flying with maximum load and can normally fly.

Mounting the LED Module

Mount the LED module in a position to ensure it remains visible during flight. The LED bracket included can be used to fix the LED module onto the aircraft.

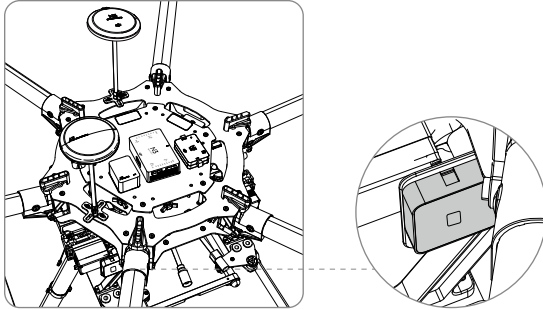

Mounting the PUM Module

Mount the PMU module to an unobstructed position on the bottom of the aircraft's upper plate for heat dissipation.

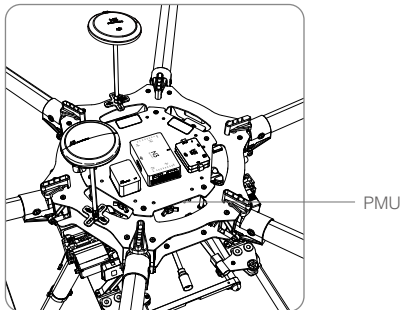

Flight Controller System Connection

Follow the below diagram to connect the flight control system, and use the cable ties to tidy the cables.

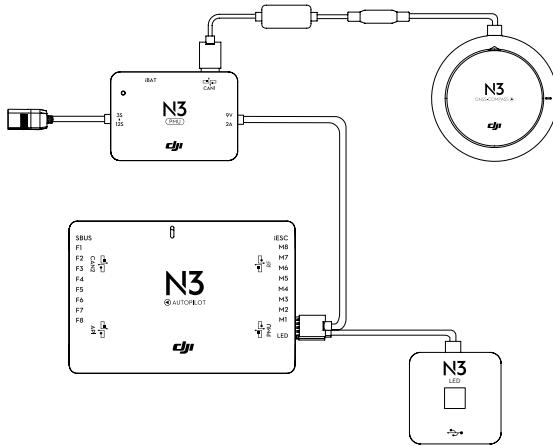

⚠ The flight control system's shell is connected to the whole system's ground.

Connecting to the Airframe and its Equipment

Ensure you have a suitable airframe, remote controller system, ESCs and battery to use with the N3 series. Strictly follow the provided guidelines. Failure to do so may lead to unexpected flight behavior or serious accidents.

Connecting to a Receiver

Select the RF port or the S-Bus port for different types of receivers.

DJI Lightbridge 2

Connect the DJI Lightbridge 2 receiver DBUS port to the Flight Controller RF Port with N3 RF Cable.

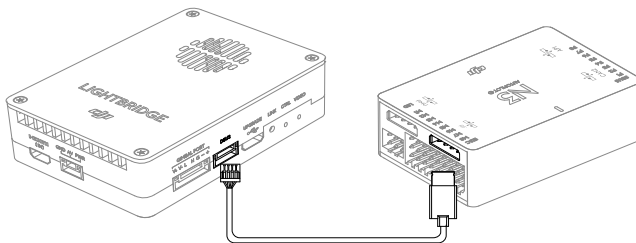

RF Cable

DR16 Receiver

Connect the DR16 receiver DBUS port to the Flight Controller S-Bus Port with a servo cable.

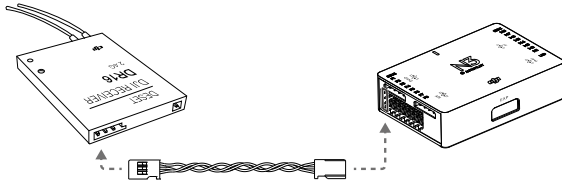

S-BUS Receiver

Connect the S-BUS receiver to the Flight Controller S-Bus Port with a servo cable.

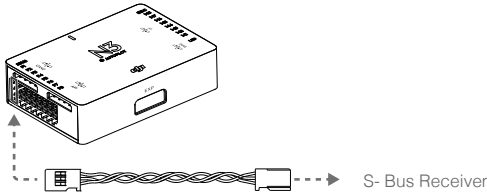

Connecting to the ESCs

S900 Connection Diagram

1. Connect the M1-M6 ports on the bottom board of the S900 to the M1-M6 ports on the Flight Controller in order.

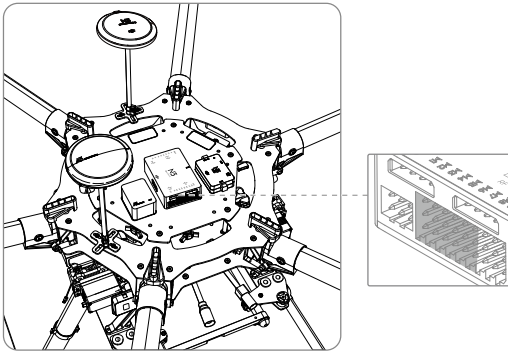

2. The iESC port can connect to the DJI Smart ESC Communication Cable if using the DJI Intelligent ESC.

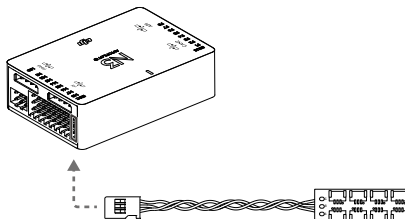

💡 • Other Airframe Type Connection Diagram

Connect the ESC ports to the ESC ports on the Flight Controller. The diagram below uses type V6 for example.

Connecting to a Battery

Connect the PMU to the Flight Controller PMU port, and then connect the battery to the PMU. Note that it can be the central board for some DJI product, e.g. DJI M600.

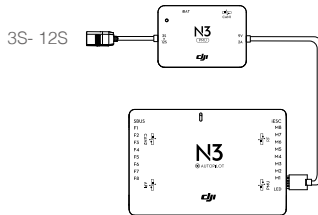

⚠️ Ensure the 3S battery voltage is higher than 11.1V, as low battery level may effect the battery life and decrease the PMU stability.

Connect to Other DJI Devices

The N3 and N3 Pro are compatible with almost all DJI devices. Connect these optional devices to the flight controller to achieve more functions. It is required to supply power for other devices as the F channel not supply power..

Intelligent Landing Gear

The N3 series supports the DJI Intelligent Landing Gear, which can be configured in DJI Assistant 2. You can use a switch to raise or lower the Intelligent Landing Gear.

Mounting and Cable Connection

Ensure the battery is powered off before connection. Connect the Intelligent Landing Gear to the flight controller's F1 port, and then configure the settings in DJI Assistant -> DJI Device -> Gear page.

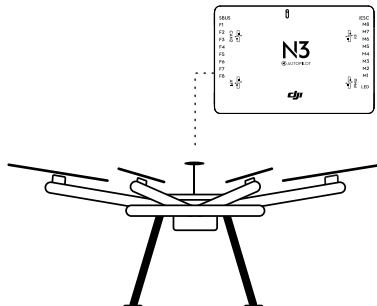

Usage

When enabled, the Intelligent Landing Gear is lowered to the ground by default or in emergency situations (e.g. motor failure tolerance, auto landing). You can use a switch to raise or lower the Intelligent Landing Gear when the aircraft's flying altitude is above 5m.

Important for DJI Assistant Settings

1. Be sure to enable and configure the Intelligent Landing Gear function in DJI Assistant first, and then connect the gear to the F1 port.
2. The Gear channel is required to be mapped to a channel on the receiver if the Intelligent Landing Gear function is enabled in DJI Assistant. Use the F1 port for landing gear output signals.
3. Unlock the landing gear in the Assistant 2 or app if landing gear folding and unfolding test is required.

Zenmuse Z15 Gimbal

The N3 and N3 Pro support the DJI Zenmuse Gimbal which can be enabled in DJI Assistant, providing gimbal rotation control during flight.

Mounting and Cable Connection

Ensure the battery is powered off before connection. Connect the gimbal to the flight controller's CAN1 port, If used with the DJI Lightbridge 2, no setting requirement. If used with other remote controller, configure the settings in the Zenmuse Z15 Assistant.

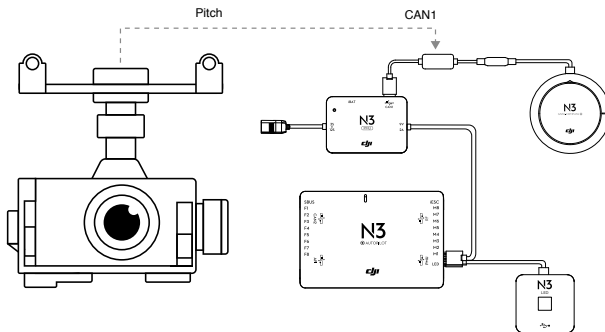

Usage

If used with the DJI Lightbridge 2, you can control the gimbal using the gimbal dial on the remote controller.

If you are not using a DJI remote controller, you will not be able to use the gimbal dial to control the gimbal.

API Devices

The API port provides support for the Onboard SDK. A Dupont cable will need to be purchased separately for connecting API devices. Be sure to connect the API port according to the pin descriptions below, and then configure the serial baud rate in DJI Assistant > SDK.

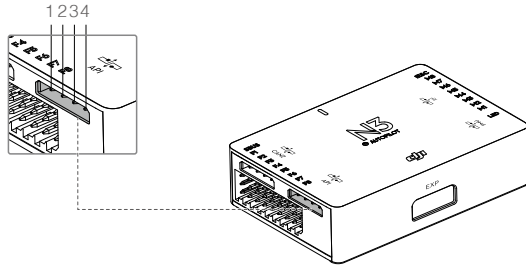

API Pin Descriptions

1. Power pin: Supply voltage of 9 V and power consumption of 9 W. If the API device does not satisfy the above voltage and consumption requirements, provide an alternate power supply.
2. GND pin: Connects to the API device's GND (ground) pin.
3. UART-TXD pin: Serial signal pin with voltage level of 3.3 V, should be connected to the API device's RXD pin.
4. UART-RXD pin: Serial signal pin with voltage level of 3.3 V, should be connected to the API device's TXD pin.

Parameter Configuration

Watch the video tutorial for a brief introduction on how to configure the parameters. Then launch DJI Assistant 2 and follow the prompts to complete configuration.

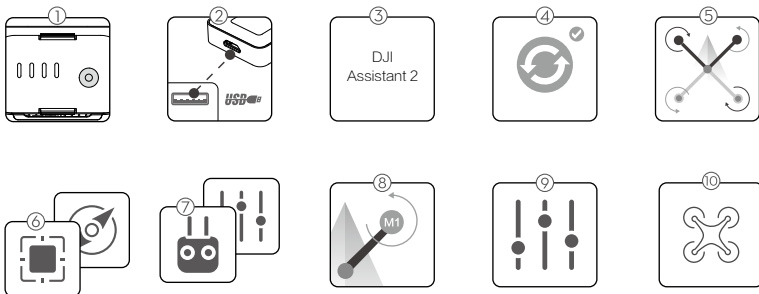

- ① Ensure the flight control system is properly powered on.
- ② Connect the Micro USB port on the LED module to a PC via a Micro USB cable.
- ③ Run DJI Assistant 2. Note that you may be asked to register for first time use.
- ④ Follow the prompts to upgrade the firmware to the latest version.
- ⑤ Select the airframe type.

- ⑥ Configure the Flight Controller, IMU and GNSS-Compass mounting parameters.
- ⑦ Select the receiver type and configure the channel mapping.
- ⑧ Make sure the motors are rotating in correct direction. If not, change the rotating direction.
- ⑨ Configure the function channels.
- ⑩ Fly in the simulator to check that all functions is working normally.



- Ensure to connect all modules before power on.
- Ensure to power cycle the battery after firmware upgrade.

N3 Functions

Compass Calibration

Ensure the compass is calibrated before every flight. Failure to calibrate may lead to poor flight performance or a crash.

1. DO NOT attempt to calibrate your compass where there is a chance of strong magnetic interference. This includes areas where there are massive metal objects, parking structures, steel reinforcements underground, or under bridges.
2. DO NOT carry ferromagnetic materials with you during calibration, such as keys or mobile phones.
3. The compass should always be calibrated when moving from indoor spaces to outdoor spaces.
4. After successful calibration, the compass may become abnormal when you place the aircraft on the ground. This may be because of underground magnetic interference. Move the aircraft to another location and try again.

Calibration Procedures

Choose an open space to carry out the following procedures.

Using the remote controller (Lightbridge 2 is used here as an example):

1. Quickly flip the control mode switch from P mode to A mode, and then back to P mode three times, and the Aircraft Status Indicator will display a solid yellow light. Flip the control mode switch between position-1 and position-3 when using the third party remote controllers.
2. Hold and rotate the aircraft horizontally 360 degrees, and the Aircraft Status Indicator will display a solid green light.
3. Hold the aircraft vertically with nose pointing downward, and rotate it 360 degrees around the center axis. Recalibrate the compass if the Aircraft Status Indicator is solid red.

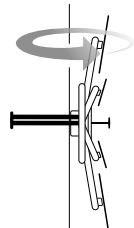
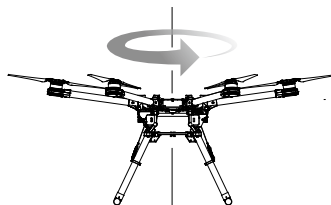
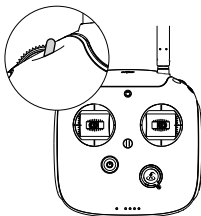

Using DJI GO (Lightbridge 2 is required):

Tap the Aircraft Status Indicator bar in the DJI GO app and select "Calibrate", then follow the on-screen instructions.

-
- ☀️:
- If the Aircraft Status Indicator blinks red and yellow after the calibration, move your aircraft to a different location to carry out compass calibration.
 - Calibrate the compass before each flight. Launch DJI GO App, follow the on-screen instructions to calibrate the compass.
-

When to Recalibrate

1. When compass data is abnormal, and the Aircraft Status Indicator is blinking red and yellow.
2. When flying in a new location, or a location that is different from your last flight.
3. When the mechanical structure of the N3 has changed, i.e. the mounting position of the compass has changed.
4. When severe drifting occurs in flight, i.e. the N3 does not fly in a straight line.

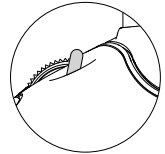

Flight Functions

Flight Modes

P-mode is preferred for most flying scenarios. Users can switch to Atti mode where and when P-mode is unavailable. Be aware that some features are NOT available in Atti mode, and take EXTRA caution when flying in Atti mode.

1. **P-mode (Positioning):** P-mode works best when the GNSS signal is strong. There are three different states of P-mode, which will be automatically selected by the flight control system depending on GNSS signal strength and Vision Positioning sensors:
 - a. **P-GPS:** GNSS and Vision Positioning are both available, and the aircraft is using GNSS for positioning.
 - b. **P-OPTI*:** If GNSS is NOT available, the aircraft will use the Vision Positioning System to hover accurately.
 - c. **P-ATTI:** When neither GNSS nor Vision Positioning is available, the aircraft is using only its barometer for positioning, so only altitude is controlled.
2. **Atti mode (Attitude):** The GNSS and Vision Positioning System are NOT used for positioning. The aircraft only uses its barometer to maintain altitude. If it is still receiving a GNSS signal, the aircraft can automatically return home if the Remote Controller signal is lost and if the Home Point has been recorded successfully.
3. **S-mode (Sports):** S-mode is identical to P-mode in terms of flight controller settings, except that the handling gain values of the aircraft are adjusted in order to enhance the maneuverability of the aircraft. The maximum flight speed of the aircraft is increased in this mode.
4. **Manual mode:** Only use it in emergency situations.

- ☀️ • P-OPTI mode is only available when a DJI Vision Positioning System is used.
- Once the GNSS signal is recovered, or the Vision Positioning System available, the Flight Control System can re-enter P-GPS mode or P-OPTI mode.
- M mode (Manual) should be enabled and set in DJI Assistant.

Aircraft Status Indicator Description

Normal

- ☀️ Green Flashes Slowly Safe to Fly (P-mode with GNSS and Vision Positioning)
- ☀️ x2 Green Flashes Twice Safe to Fly (P-mode with Vision Positioning but without GNSS)
- ☀️ Yellow Flashes Slowly Safe to Fly (A mode but No GNSS and Vision Positioning)

Flight Control

Manual Take-off

Start the motors by pulling both control sticks to the bottom inside (or outside) corners. Release the sticks once the motors start. Slowly push the left stick (throttle stick) up to takeoff.

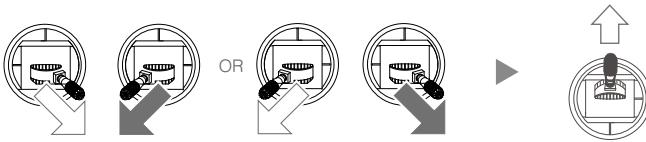

Remote Controller Operation

Here are the default flight controls (Mode 2). The left stick controls altitude and rotation, while the right stick controls the forward, backward, left or right movements. The gimbal dial controls the camera's tilt.

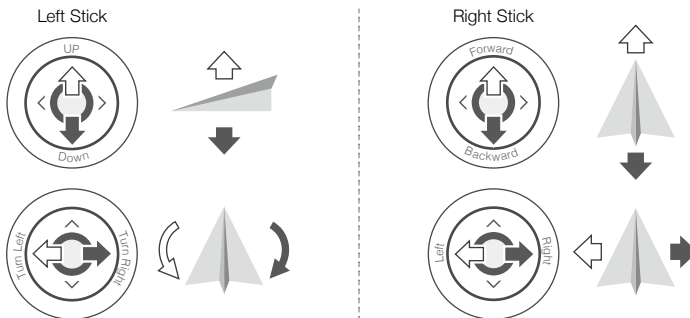

- ☀️ • You can customize or change these controls through the DJI GO app.

Manual Landing

Use the below method to stop the motors:

When the aircraft has landed, push the throttle down and hold. The motors will stop after 3 seconds.



You can use the below method to stop the motors in the event of an emergency.

When the aircraft has landed, push the throttle down, then perform the CSC (Control Stick Combination). The motors will stop immediately. Release both sticks once the motors have stopped.

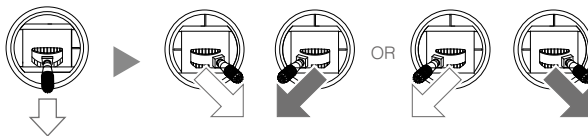

Intelligent Flight Modes (using the Remote Controller)

Intelligent Flight Modes make it easier to operate the aircraft. If you are not using a Lightbridge 2 remote controller, you will need to configure a 3-position switch on the remote controller as the Intelligent Flight Modes Switch, with each switch position corresponding to one of the following modes: Off, Course Lock, or Home Lock.

Course Lock

Use Course Lock to lock the current nose direction as the aircraft's forward direction. The aircraft will move in the locked direction regardless of its orientation (yaw angle).

Requirements: Compass must be working properly.

How to operate: 1. Fly the aircraft in the direction you wish to lock; 2. Toggle the Intelligent Flight Modes Switch to the Course Lock position to lock the current nose direction as the aircraft's forward direction.

How to reset the parameters: Aircraft nose orientation cannot be reset during flight.

How to stop or exit the flight mode: Toggle the Intelligent Flight Modes Switch to the Off position.

Home Lock

Pull the pitch stick backward to move the aircraft toward its recorded Home Point.

Requirements: Home point recorded; P-GPS mode enabled; distance between the aircraft and Home Point is greater than 5 meters.

How to operate:

1. Fly the aircraft to the target position;
2. Toggle the Intelligent Flight Modes Switch from the Off position to the Home Lock position for more than three times to record the Home Point (Note: the Intelligent Flight Modes Switch should stop at the Off position);

3. Flip the Intelligent Flight Modes Switch to the Home Lock position to start the flight.

How to reset the parameter: Parameters cannot be reset during flight.

How to stop or exit the flight mode: Toggle the Intelligent Flight Modes Switch to the Off position.



- Lightbridge 2 not only allows you use the DJI GO app to operate the aircraft, but also use Intelligent Flight Modes, such as Course Lock, Home Lock, Point of Interest (POI) and Waypoints, to capture professional shots during flight.

Protection Functions

Return to Home

Return to Home (RTH) brings the aircraft back to the last recorded Home Point. There are three cases that will trigger the RTH procedure; they are Failsafe RTH, Smart RTH and Low Voltage RTH.

Failsafe RTH

Failsafe RTH is activated automatically if the remote controller signal (including video relay signal if DJI Lightbridge 2 used) is lost for more than 3 seconds, provided that the Home Point has been successfully recorded and the compass is working normally. The RTH process may be interrupted and the operator can regain control over the aircraft if a remote controller signal is resumed.

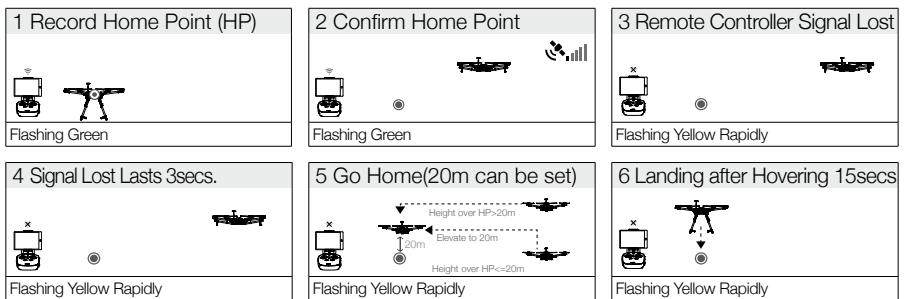

- The aircraft automatically descends and lands if RTH is triggered when the aircraft flies within a 65-foot (20-meter) radius of the Home Point.
- The aircraft cannot return to home if the LED is slowly blinking yellow or the GNSS does not work.
- The aircraft cannot avoid obstacles during Failsafe RTH. Therefore it is important to set a reasonable Failsafe altitude before each flight. Launch the DJI GO app and enter "Camera" view and select "MODE" to set the Failsafe altitude.
- The aircraft will stop ascending and immediately return to the Home Point if you move the throttle stick when the aircraft reaches an altitude of 20 m or above during Failsafe.

Smart RTH

Use the RTH button on the remote controller when GNSS is available to enable Smart RTH. During the Smart RTH procedure, the aircraft returns to the last recorded Home Point but you may control the aircraft's orientation to avoid collisions. Press the Smart RTH button once to start the process. Press the Smart RTH button again to exit Smart RTH and regain the control.

-
-  If using the DJI Lightbridge 2, no additional settings are required for the RTH button. If using another type of remote controller, you must configure the RTH button in DJI Assistant 2.
-

Low Battery RTH with LiPo battery

The low voltage failsafe is triggered when the LiPo Battery is depleted to a point that may affect the safe return of the aircraft. Users are advised to return home or land the aircraft immediately when these warnings are shown. Aircraft will automatically return to the Home Point if no action is taken after 10 seconds countdown. Cancel the RTH procedure by pressing once on the RTH button. The thresholds for these warnings are automatically determined based on the current aircraft altitude and its distance from the Home Point.

Aircraft will land automatically only if the current voltage can support the aircraft in landing on the ground from the current altitude. Use the remote controller to control the aircraft's orientation during the landing process.

-
-  When the critical battery level warning activates and the aircraft is descending to land automatically, you may push the throttle upward to hover the aircraft and navigate it to a more appropriate location for landing.
-

Attitude Control When One Motor Output Fails

For hexa-rotor and quad-rotor, the N3 flight control system can control the aircraft's attitude when one motor fails:

1. During flight, the aircraft with N3 flight control system is attitude controllable when one motor output fails
2. The motor will not start before take-off. (DJI Intelligent ESCs are required for communication.) Select Course Lock or Home Lock mode to fly the aircraft to a safe area to land when the aircraft is far away, or the attitude can't be recognized.

Propulsion System Protection

Low voltage and overweight aircraft warnings are provided in the DJI GO app.

Flight Limits and Flight Restriction Areas

Flight limits on height and distance can be set. The details of these flight limits are described in the following section.

All unmanned aerial vehicle (UAV) operators should abide by all regulations from such organizations as the ICAO (International Civil Aviation Organization), FAA and their own national airspace regulations. For safety reasons, the flight limits function is enabled by default to help users use this product safely and legally. The flight limits function includes height limits, distance limits and No Fly Zones. When operating in P Mode, height, distance limits and No Fly Zones work together to manage flight. In A mode only height limits work and flights cannot go higher than 120 meters* (can be set up to 500 meters in the Assistant or DJI GO app).

*It is 50 meters if the GNSS Level does not reach 3-level (or above) during flight.

Max Height & Radius Limits

Max Height & Radius limit flying height and distance. Once complete, your aircraft will fly in a restricted cylinder that is determined by these settings. The tables below show the details of these limits.

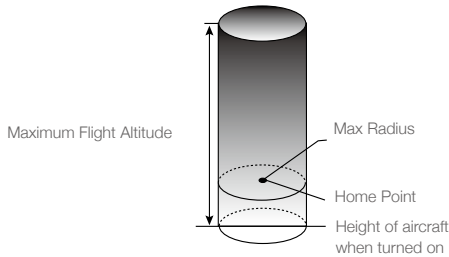

GNSS Signal Strong  Slowly Blinking Green			
	Flight Limits	DJI GO app	Aircraft Status Indicator
Maximum Flight Altitude	Aircraft's altitude cannot exceed the specified value.	Warning: Height limit reached.	None.
Max Radius	Flight distance must be within the max radius.	Warning: Distance limit reached.	None.

GNSS Signal Weak  Slowly Blinking Yellow

	Flight Limits	DJI GO app	Aircraft Status Indicator
Maximum Flight Altitude	Height is restricted to 400 feet. (120m) and under.	Warning: Height limit reached.	None.
Max Radius	No limits		

-  • If the aircraft flies out of the limit, you can still control the aircraft, but you cannot fly it any farther.
- If the aircraft flies out of the max radius it will fly back within range automatically when GNSS signal is strong.

No-Fly Zones

All No-Fly Zones are listed on the DJI official website at <http://www.dji.com/flysafe/no-fly>. No-Fly Zones are divided into Airports and Restricted Areas. Airports include major airports and flying fields where manned aircraft operate at low altitudes. Restricted Areas include border lines between countries or sensitive institute. The details of the No-Fly Zones are explained as follow:

Airport



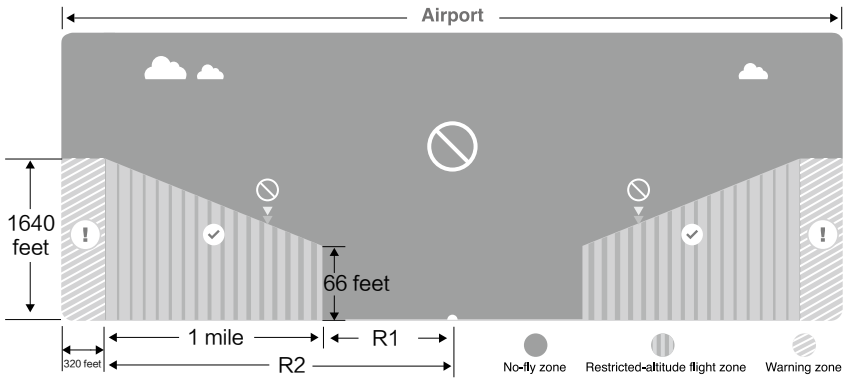



- (1) Airport No-Fly Zone are comprised of Take-off Restricted zones and Restricted Altitude Zones. Each zone features circles of various sizes.
- (2) R1 miles (value of the R1 depends on the size and shape of the airport) around the airport is a Take-off restricted zone, inside of which take off is prevented.
- (3) From R1 mile to R1 + 1 mile around the airport the flight altitude is limited to a 15 degree inclination. Starting at 65 feet (20 meters) from the edge of airport and radiating outward. The flight altitude is limited to 1640 feet (500 meters) at R1+1 mile
- (4) When the aircraft enters within 320 feet (100 meters) of No-Fly Zones, a warning message will appear on the DJI GO app.

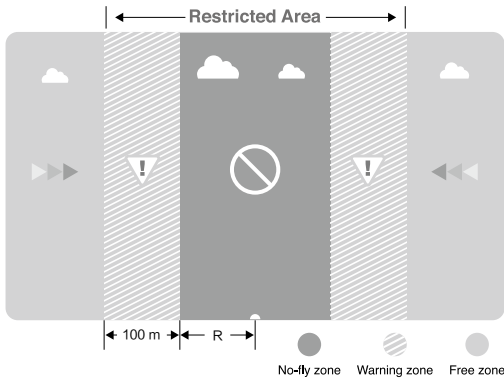



Restricted Area

- (1) Restricted Areas does not have flight altitude restrictions.
- (2) R miles around the designated restriction area is a Take-off Restricted area. Aircraft cannot take off within this zone. The value of R varies based on the definition of the restricted areas.
- (3) A "warning zone" has been set around the Restricted Area. When the aircraft approaches within 0.062 miles (100 m) of this zone, a warning message will appear on the DJI GO app.



GNSS Signal Strong  Blinking Green				
Zone	Restriction	DJI GO app Prompt	Aircraft Status Indicator	
No-fly Zone 	Motors will not start.	Warning: You are in a No-fly zone. Take off prohibited.	 Red flashing	
	If the aircraft enters the restricted area in A-mode, but is switched to P-mode, the aircraft will automatically descend, land, and stop its motors.	Warning: You are in a no-fly zone. Automatic landing has begun.		
Restricted-altitude flight zone 	If the aircraft enters the restricted area in A-mode, but is switched to P-mode, it will descend to an appropriate altitude and hover 15 feet below the altitude limit.	R1: Warning: You are in a restricted zone. Descending to safe altitude. R2: Warning: You are in a restricted zone. Maximum flight altitude is restricted to between 20m and 500m. Fly cautiously.		
Warning zone 	No flight restriction applies, but there will be a warning .	Warning: You are approaching a restricted zone, Fly cautiously.		
Free zone 	No restrictions.	None.		None.

 Semi-automatic descent: All stick commands are available except the left stick command during the descent and landing process. Motors will stop automatically after landing.

-  • When flying in a safety zone, the aircraft's status indicator will blink red rapidly and continue for 3 seconds, then switch to indicate current flying status and continue for 5 seconds at which point it will switch back to blinking red.
- For safety reasons, please do not fly close to airports, highways, railway stations, railway lines, city centers, or other sensitive areas. Fly the aircraft only within your line of sight.

Using with DJI GO app

Intelligent Flight Modes are available in the DJI GO app when using the DJI Lightbridge 2.

Download the DJI GO App

Search “DJI GO” on the App Store or Google Play and download the app to your mobile device.



For the best user experience, please use mobile devices with iOS 8.0 (or higher) and Android 4.1.2 (or higher).

Beginner Mode

The N3 will enter Beginner Mode the first time you use the DJI GO app, which can be canceled on the “MODE” page. In Beginner Mode, the Max Height and Max Distance are restricted to 30 meters.

Auto Take-off

Use auto take-off to take off your aircraft automatically if the Aircraft Status Indicator is blinking green. Follow the steps below to use auto take-off:

1. Launch DJI GO app, enter “Camera” view.
2. Ensure the aircraft is in “P” mode.
3. Go through the pre-flight checklist.
4. Tap “”, and confirm flight conditions. Slide to confirm and take-off.
5. Aircraft takes off and hovers at 1.2 meters above ground.

Auto-Landing

Use auto-landing to land your aircraft automatically if the Aircraft Status Indicator is blinking green. Follow the steps below to use auto-landing:

1. Ensure the aircraft is in “P” mode.
2. Check the landing area condition before tapping “”, to perform landing.
3. Aircraft lowers the landing gear and proceed to land automatically.

Updating the Home Point

There are two ways for updating the Home Point.

1. Update the Home Point via DJI GO app when using with Lightbridge 2.
2. Quickly flip the F-switch more than three times to update the Home Point when using a non-DJI receiver.

The aircraft status indicator blinks green to show Home Point is set successfully.

Return to Home

Smart RTH, Low Voltage RTH and Failsafe RTH are also available in the DJI GO app.

Smart RTH

Press the Return-To-Home button to bring the aircraft back to the Home Point. Tap again to stop the procedure.

Low Voltage RTH

The low voltage failsafe is triggered when the LiPo Battery is depleted to a point that may affect the safe return of the aircraft. Users are advised to return home or land the aircraft immediately when these warnings are shown. DJI GO will advise users to return the aircraft to the Home Point when the low voltage warning is triggered. Aircraft will automatically return to the Home Point if no action is taken after a 10-second countdown. Cancel the RTH by pressing once on the RTH button. The thresholds for these warnings are automatically determined based on the current aircraft altitude and its distance from the Home Point.

Aircraft will land automatically if the current voltage can only support the aircraft to land to the ground from the current altitude. Use the remote controller to control the aircraft's orientation during the landing process.



When the critical low voltage warning activates and the aircraft is descending to land automatically, you may push the throttle upward to hover the aircraft and navigate it to a more appropriate location for landing.

Failsafe RTH

The aircraft will not avoid obstacles while it is returning to the Home Point, and an appropriate RTH altitude **MUST** be set before flight. Launch the DJI GO app and enter Camera view and select "MODE" to set the Failsafe altitude. You should also use the control sticks to guide the aircraft. Refer to the Safety Guidelines and Disclaimer for more details.

Intelligent Flight Modes (in DJI GO app)

Course Lock

Lock the current nose direction as the aircraft's forward direction. The aircraft will move in the locked directions regardless of its orientation (yaw angle).

Conditions of Use: Compass is working normally.

How to operate: Control the aircraft nose orientation-> Tap the Course Lock icon to start the Course Lock flight.

How to reset the parameter: Aircraft nose orientation cannot be reset during flight.

How to stop or exit the flight mode: Click the "Exit" button during flight.

Home Lock

Pull the pitch stick backward to move the aircraft toward its recorded Home Point.

Conditions of Use: Home point recorded; in the P-GPS mode; distance between the aircraft and home point is larger than 5 meters.

How to operate: Tap the Home Lock icon to start.

How to reset the parameter: None.

How to stop or exit the flight mode: Click the "Exit" button during flight.

POI (point of interest)

The aircraft will orbit around the subject automatically to allow the operator can be more focus on framing their shoot on the subject in Point of Interest.

Conditions of Use: in the P-GPS mode; distance between the aircraft and interest point is larger than 5 meters and smaller than 10 meters.

How to operate: Set the interest point -> Operate the aircraft to set the distance and the flight velocity -> Tap the POI icon to start the flight.

How to reset the parameter: The distance and the flight velocity can be changed during the flight when you operate the aircraft.

How to stop or exit the flight mode: Click the "Exit" button during flight.

Waypoints

Record a flight path, then the aircraft will fly along the same path repeatedly while you control the camera and orientation. The flight path can be saved and re-applied in the future.

Conditions of Use: in the P-GPS mode; Distance between the way points is larger than 5 meters and less than 500 meters; automatically detect the voltage.

How to operate: Operate the aircraft to the target position and set the aircraft nose orientation -> Tap to record the waypoints-> Set the Waypoint mode (Consistent with record, Consistent with route, Free) -> Set the flight velocity and Failsafe option->Save in the App-> Start.

How to reset the parameter: The aircraft orientations are different in each mode. Operate the aircraft to fly forwards or backwards.

How to stop or exit the flight mode: Click the "Exit" button during flight.

Difference between the three modes:

Free: The aircraft nose can be changed during the waypoint flight.

Consistent with record: Aircraft nose orientation of every waypoint are pre-recorded. And the aircraft nose will automatically change to the recorded orientation during flight.

Consistent with record: Aircraft nose orientation keep the same as the route direction. The aircraft nose will automatically change during flight.

⚠ If the detected voltage is too low, the aircraft will not enter the Waypoints flight mode.

iOSD

DJI Lightbridge 2 **MUST** be connected to for the built-in iOSD to work. Most flight information is displayed on-screen in the DJI GO app.

Information displayed includes voltage, flight velocity, height, distance from the home point, horizontal attitude, GPS satellite number, etc. iOSD and video information are superposed on the receiver, making iOSD data clearly visible and bringing you a more involved flight experience.

☀ N3 supports DJI iOSD Mark II and iOSD mini.

Used with the A3 Upgrade Kit

With the A3 upgrade kit (IMU Pro and GPS-Compass Pro modules), the N3 provides triple modular redundancy, improving the system's anti-risk performance. System status is indicated by LEDs on the GPS-Compass Pro, IMU Pro and Flight Controller modules.

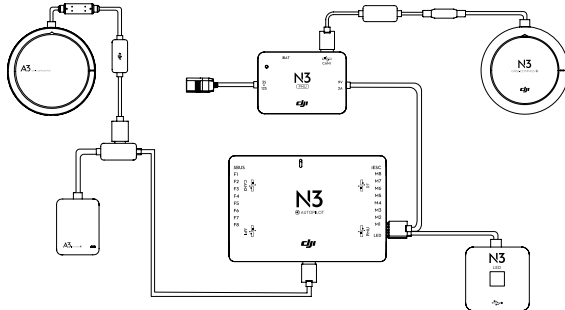

LED Indicator	Status
☀ Green	The module is functioning normally and working as a part of the system When the LED is blinking green.
⚠ Red	The module is functioning abnormally When the LED is blinking red.
⚡ Blue	The module is functioning normally but not working as a part of the system When the LED is blinking blue.

SDK

An independent CAN2 port, API Serial port and USB OTG port are provided for SDK support. The CAN2 port lets you connect SDK devices and support for open protocols enables greater customization.

Refer to the DJI official website <https://developer.dji.com/> for more SDK details.

Flight Control System Checklist

Hardware Checklist

Mounting and components checklist

1. Ensure all parts are mounted correctly and firmly.
2. Ensure the ESCs and receiver are connected correctly and firmly.

LED Status checklist

1. Ensure the mode switch corresponds to the flight status LED.
2. System status LED on the GNSS-Compass and IMU Pro are normal.
3. Ensure all the sensor parameters are correct and the IMUs are calibrated correctly.

DJI Assistant 2 Checklist

DJI Assistant 2 checklist

1. Ensure the aircraft mounting parameters are correct.
2. Ensure the flight controller parameters are correct.
3. Low voltage level protection and Failsafe protection are set correctly.















Flight Safety

It is important to understand basic flight guidelines for the safety of both you and those around you. Refer to the Disclaimer and Safety Guidelines for more information.



Appendix

LED Indicators

Flight Status LED Indicator

LED	Description
 Blinking Red, Green and Yellow Alternately	The system is running a diagnostic test.
 × 4 Blinking Yellow Four Times	The system is warming up.
 Blinking Green Slowly	Safe to fly, GNSS working
 Blinking Yellow Slowly	P-ATTI or ATTI mode
 × 2 Blinking Green Quickly Twice	VPS working, no GNSS
 Blinking Purple Twice	Manual mode
 Blinking Blue Rapidly for 1.5 seconds	Switching devices (IMU or GNSS modules) for the modular redundancy system
 Blinking Green Rapidly for 1.5 seconds	Home Point/POI/Course Orientation is set successfully
 Blinking Yellow (Alternates with other flight mode patterns)	Intelligent Flight Modes
 Blinking Yellow Rapidly	Remote controller signal lost
 Blinking Red Slowly	Low voltage warning
 Blinking Red Rapidly	Critically low voltage warning
 Blinking Red Rapidly for 0.6 second when performing CSC	Large IMU bias or IMU initialization
 Solid Red	Critical error
 Blinking Red and Yellow Alternately	Compass calibration required

GNSS-Compass/A3 IMU Pro/A3 GPS-Compass Pro/IMU Pro/Flight Controller LED Indicator

LED Indicator	Status
 Green	The module is functioning normally and working as a part of the system When the LED is blinking green.
 Red	The module is functioning abnormally When the LED is blinking red.
 Blue	The module is functioning normally but not working as a part of the system When the LED is blinking blue.

Troubleshooting

1. LED Status checklist

Ensure the mode switch corresponds to the flight status LED.

Ensure the system status LEDs on the GNSS-Compass and IMU Pro are normal.

Ensure all the sensor parameters are correct and the IMUs are calibrated correctly.

2. IMU calibration failure.

Ensure the aircraft is not moved during calibration.

Ensure the aircraft is placed level during calibration.

3. Voltage detection error.

Connect to DJI Assistant 2 to ensure the battery type is correct.

4. Compass calibration failure.

Restart the battery if compass calibration failed.

Connect to DJI Assistant 2 to ensure the channel mapping of the flight mode switch is correct.

Connect to DJI Assistant 2 to ensure the compass Mod value is normal.

5. Failed to exit the SD card read mode after reading the SD card successfully.

Restart the battery of the aircraft.

Specifications

Built-in Functions		
Flight Modes	P-mode (Positioning)	
	A-mode (Attitude)	
	S-mode (Sport)	
	Manual mode	
Return-to-Home Modes	Smart RTH	
	Low voltage RTH	
	Failsafe RTH	
Safety Features	Failsafe mode	
	Low battery voltage warning	
	Custom flight altitude and radius limits	
	No Fly Zones	
	Motor redundancy (for 6 and 8 rotor platforms)	
	Motor overload detection	
	Multi modular redundancy (with the A3 upgrade kit)	
DJI GO App (DJI Lightbridge 2 required)	Beginner mode	
	Auto takeoff and landing	
	Wireless flight controller configuration	
	Flight data OSD (built-in data recorder)	
	Intelligent Flight Modes	Course Lock*
		Home Lock*
		Point of Interest (POI)
Waypoints		
Supported DJI Equipment	DJI aerial platforms (e.g. S900, S1000, S1000+)	
	DJI gimbal systems (e.g. Zenmuse X3 / X5 / X5R/ XT /Z15 A7 / GH4 / 5D III / BMPCC)	
	DJI Intelligent Landing Gear	
	DJI iOSD Mark II, DJI iOSD mini	

*Course Lock and Home Lock work without the DJI Lightbridge 2.

Peripheral	
Supported Airframes	4-rotor: I4, X4 6-rotor: I6, V6, Y6, IY6 8-rotor: X8, I8, V8, IX8
Supported ESC output	400 Hz refresh frequency
Supported Receivers	DJI Lightbridge 2 DJI DR16 S-Bus
Recommended Batteries	3S-12S LiPo battery
Required Operation System	Windows 7, 8 or 10 (32 or 64 bit) Mac OS X 10.9 or later
SDK	Mobile SDK Onboard SDK
Onboard SDK Ports	API, CAN2*
Expansion Ports	F1-F4 ports for output F5-F8 ports for I/O*

*Coming soon.

Electrical & Mechanical	
Rated Power	3.3 W
Rated Peak Power	5 W
Input Voltage Range	10.5 – 52 V
Static Electricity	AD: ±8 kV CD: ±4 kV
Operating Temperature	14° to 131° F (-10° to 55° C)
Weight	Flight Controller: 46 g GNSS-Compass: 37 g LED Module: 13 g PMU: 33 g
Dimensions	Flight Controller: 58.1 mm × 39 mm × 17.05 mm GNSS-Compass: 50 mm (diameter) × 12.2 mm LED Module: 25 mm × 25 mm × 6.3 mm PMU: 40 mm × 28.5 mm × 11.2 mm

Optimized Flight Performance (Subject to airframe type and payload, most parameters can be configured in Assistant 2.)

Hovering Accuracy (In P-Mode)	Vertical: ± 0.5 m Horizontal: ± 1.5 m
Max Wind Resistance	10 m/s
Max Yaw Angular Velocity	150°/s
Max Pitch Angle	45 (Default 35°)
Max Ascent Velocity	5 m/s
Max Descent Velocity	4 m/s

DJI Support

<http://www.dji.com/support>

This content is subject to change.

Download the latest version from
<http://www.dji.com/product/n3>



If you have any questions about this document, please contact DJI by sending a message to DocSupport@dji.com.

© 2016 DJI All Rights Reserved.