

Zenmuse Z15-BMPCC

User Manual

V1.0

May 09, 2014

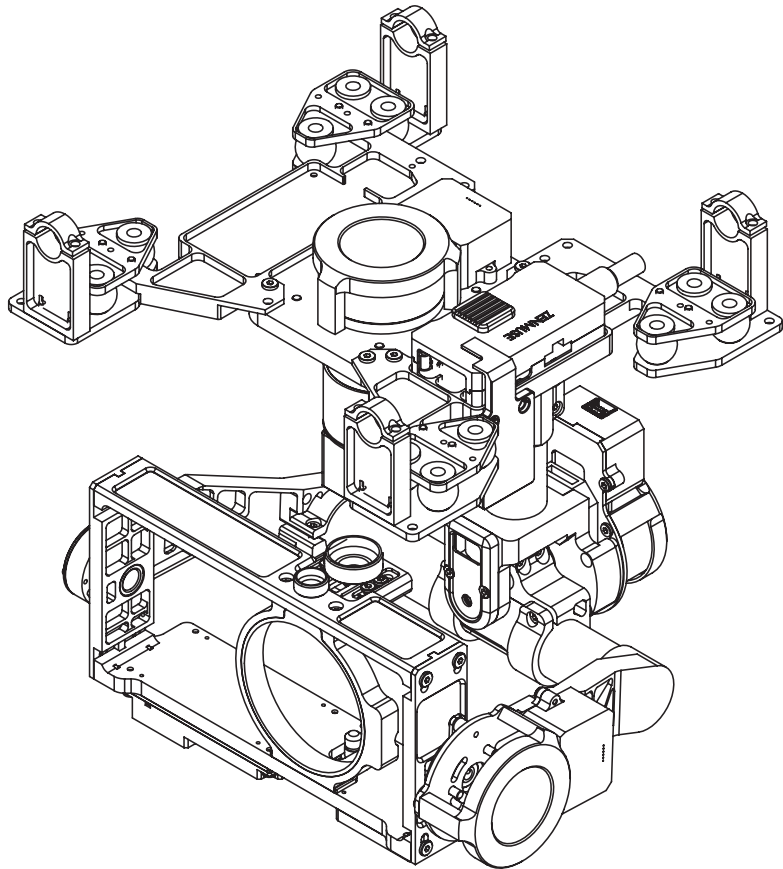

Warning & Disclaimer

Do not modify or adjust the Z15-BMPCC.

The Z15-BMPCC has been calibrated specifically for the designated Camera and Lens before it leaves the factory. Please mount only the designated camera and lens to the Z15-BMPCC. No adjusting or amending is allowed to the Z15-BMPCC. Do not modify or add any other component/device (such as filters, lens hood, etc.) to the camera. Make sure to use the original camera battery, otherwise performance may be hindered and also possibly cause internal malfunctions and damage to the gimbal. The Z15-BMPCC can only work with Flight Control Systems developed by DJI (A2/ WooKong M: **please upgrade to the latest Flight Control System firmware**), so as to ensure the highest amount of stability and precision. Please download the corresponding Assistant Software and upgrade the Flight Control System's MC firmware, otherwise the Z15-BMPCC will work abnormally. Make sure the Flight Control System operates in the safest manner when the main battery power is connected. We strongly recommend users to remove all propellers and use the power supply from the R/C system or flight pack battery and keep children away during gimbal calibration and parameter setup. Follow these steps to mount and connect the gimbal to your aircraft as well as during the installation of the Assistant Software on your computer. Please respect the AMA's National Model Aircraft Safety Code.

As DJI has no control over use, setup, final assembly, modification (including use of non-specified DJI parts i.e. motors, ESCs, propellers, etc.) or misuse, no liability shall be assumed nor accepted for any resulting damage or injury. By the act of use, setup or assembly, the user accepts all resulting liability. DJI assumes no liability for damage(s) or injuries incurred directly or indirectly from the use of this product.

DJI and Zenmuse are registered trademarks of DJI as names of product, brand, etc., appearing in this manual are trademarks or registered trademarks of their respective owner companies. This product and manual are copyrighted by DJI with all rights reserved. No part of this product or manual shall be reproduced in any form without the prior written consent or authorization of DJI. No patent liability is assumed with respect to the use of the product or information contained herein.

Specified Camera and Lens Type list for Z15-BMPCC

Camera Type Blackmagic Pocket Cinema Camera (BMPCC)

Lens Type OLYMPUS M.ZUIKO DIGITAL ED 12mm f/2.0

Firmware versions of supporting DJI Flight control systems

WooKong: V5.26 **A2:** V2.1

Manual Tips

Legends



Important



Tips

Product Profile

The Z15-BMPCC is a sophisticated, technologically advanced, class leading gimbal designed specifically for aerial creativity. It has a built-in independent IMU module, special servo drive module, HDMI HD/AV module, and more. The Z15-BMPCC performs well in all modes, including Orientation-locked, Non orientation-locked and FPV (Reset).

Working Modes			
	Orientation-locked	Non orientation-locked	FPV (Reset)
Gimbal Direction	Gimbal pans with aircraft nose.	Gimbal pan and aircraft nose move separately.	Gimbal pan and aircraft nose are synchronized.
Gimbal and Aircraft Nose Relative Angle	Gimbal keeps the same relative angle with aircraft nose.	Relative angle between gimbal direction and aircraft nose is controllable.	The relative angle between gimbal direction and aircraft nose is 0°.
TX Control	Controllable	Controllable	Uncontrollable
Attitude Stability*	YES	YES	YES
Vibration Reduction	YES	YES	YES
Stick Movement Definition	ROLL is locked level in 0~2/3 stick command and rotates in 2/3 ~endpoint; stick command moves the rotation angle which is limited to 40° in PAN; stick command moves the TILT rotation velocity of the gimbal.	Stick command for gimbal rotation velocity is relative to total stick movement. Stick's center position is 0°/s. Its endpoint moves to the maximum velocity.	_____
Command Linearity	YES	YES	_____

Note*: Attitude stability means that gimbal's ROLL/TILT will not follow the aircraft's ROLL/PITCH movement.

In the Box

Gimbal x1

The gimbal includes built-in Z15-BMPCC DJI servo drive modules and an independent IMU module and HDMI-HD/AV module.

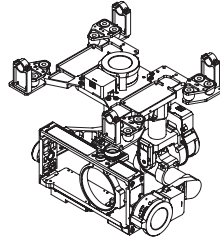

Gimbal Controller Unit (GCU) x1

Connect the GCU to the Flight Control System using the CAN-Bus. The GCU will control the gimbal's pan, roll and tilt movements.

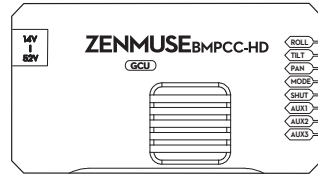

Lens Retaining Ring x1

Mounting the camera lens.

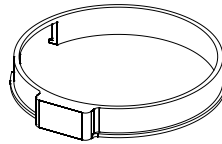

Mounting Bracket x4

Mounting the gimbal to landing gear.



Mounting Board for Receiver x1

Attaching the GCU and providing a convenient mount for the receiver or other devices.

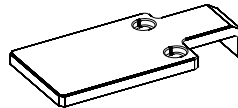

Cable Clamp x1

Cable management.



Camera Mount Screw x2

Standard tripod mount on the camera.

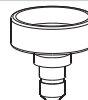

Lens Retaining Ring Screw x1

Attaching the lens retaining ring to the gimbal.

**Screw Package x1**

Mounting gimbal to aircraft (M2.5*8 cap head screw).

**9-Pin Cable x2**

Connecting GCU to gimbal.

**7-Pin Cable x1**

Connecting GCU to Lightbridge air system.

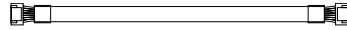
**6-Pin Cable x2**

Connecting GCU to gimbal.

**Camera Record Control Cable x1**

Connecting gimbal HDMI/AV unit to camera.

**Servo Cable Package x1**

Connecting GCU and receiver.

**AV Video Power Cable x1**

Connection between GCU and Wireless Video Transmission Module transmitting the AV signal.

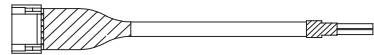
**iOSD Mark II Cable x1**

Connecting GCU and DJI iOSD MarkII.

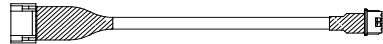
**Micro-USB Cable x1**

Adjusting parameters and upgrading firmware via a PC.

**CAN-Bus Cable x1**

CAN-Bus – Flight Control System communication.

**Spare Package x1**

Vibration Absorbers, Spare Screws, and Mounting Bracket.

Contents

Warning & Disclaimer	2
Manual Tips	2
Legends	2
Product Profile	3
In the Box	4
Contents	6
Gimbal Description	7
Mount	8
Mounting Lens Retaining Ring into Gimbal	8
Mounting Camera into Gimbal	9
Mounting Gimbal to Landing Gear	9
Camera Wiring/Record Control	11
Camera Wiring	11
Record Control	11
Video Signal Transmission	12
A.AV wireless video transmission	12
B.DJI iOSD Mark II and AV wireless video transmission	13
C.DJI Lightbridge Air System	13
GCU Wiring	15
GCU Ports Indication	16
Working Modes/AUX1/AUX2 Switch Setup	16
Working Mode Switch Set	16
AUX1 Switch Set	17
AUX2 Switch Set	17
Assistant Software Installation and Usage	18
Pre-Flight Check	18
Check Before Each Flight	18
Flight Test	18
Appendix	20
Attention	20
1-Pilot Solution	20
2-PILOT SOLUTION	21
Port Description	22
Gimbal LED Indicator	22
Trouble Shooting	23
Specifications	24

Gimbal Description



- Ensure nothing blocks servo drive modules during rotation to avoid motor damage.
- Clear obstacles or immediately cut power if blockage occurs.



- Servo drive module has two motor command input ports and one private encoder port.
- HDMI-HD/AV module converts HDMI to HD (or AV) using a cable connected to the camera HDMI port. It also transforms the TX signal into a record control signal with a record control cable.
- The camera record control cable is removable. Unplug it if record control is not needed.

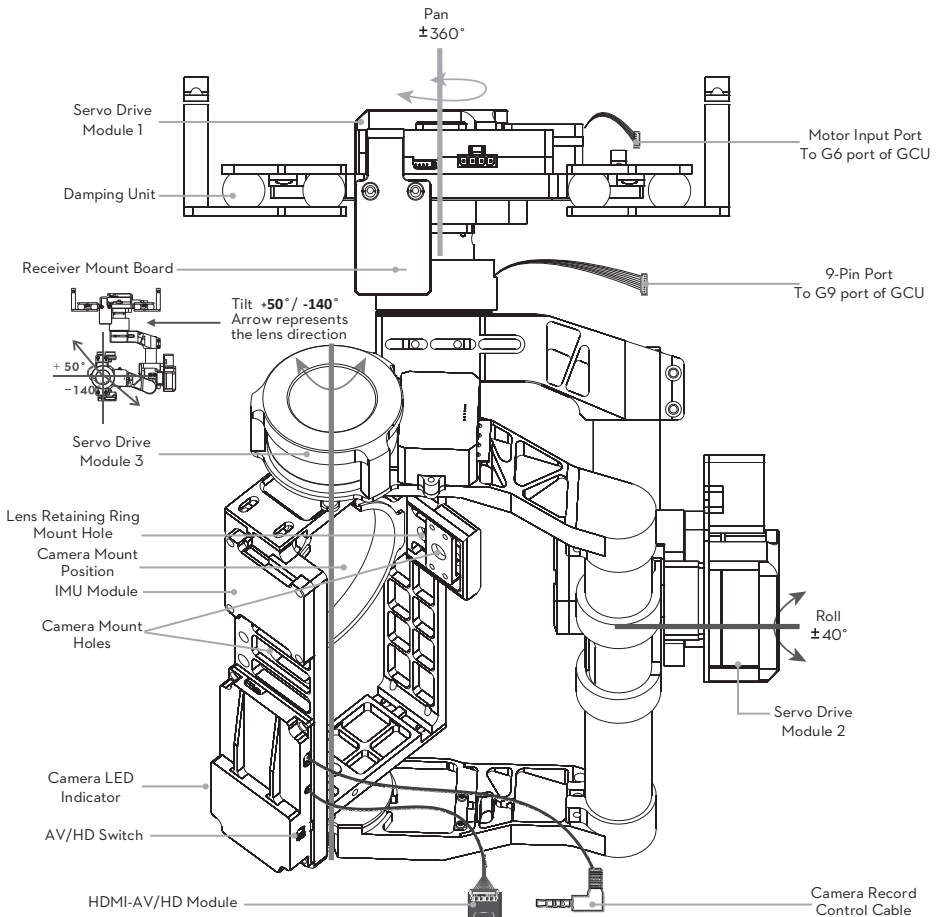

Mount

step1: Mount the lens onto the camera.

Mounting Lens Retaining Ring into Gimbal

step2: Mount the Lens Retaining Ring into the Gimbal as shown in the diagram.

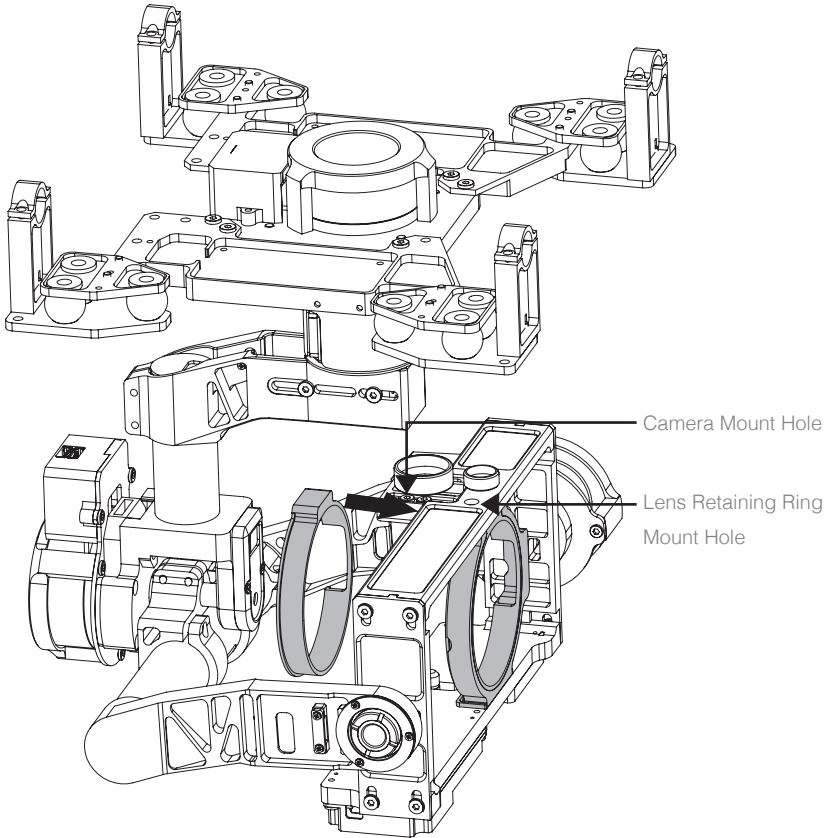

Mounting Camera into Gimbal

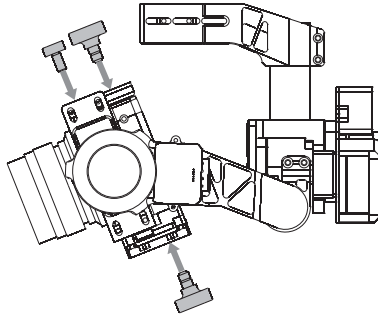

step3: Mount camera into gimbal.

step4: Adjust camera and tighten the top camera mounting screw. Tighten the bottom camera mounting screw and the lens retaining ring screw.

Mounting Gimbal to Landing Gear

The following diagram shows the gimbal mounted on a DJI S800 EVO.

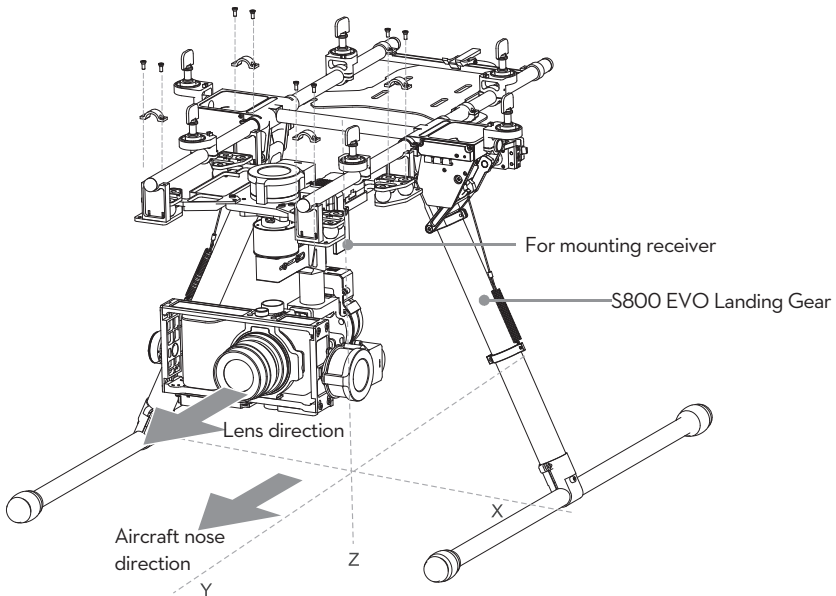

The following diagram shows the gimbal mounted on a DJI S1000. You may also mount it to different landing gear by referring to the diagram.

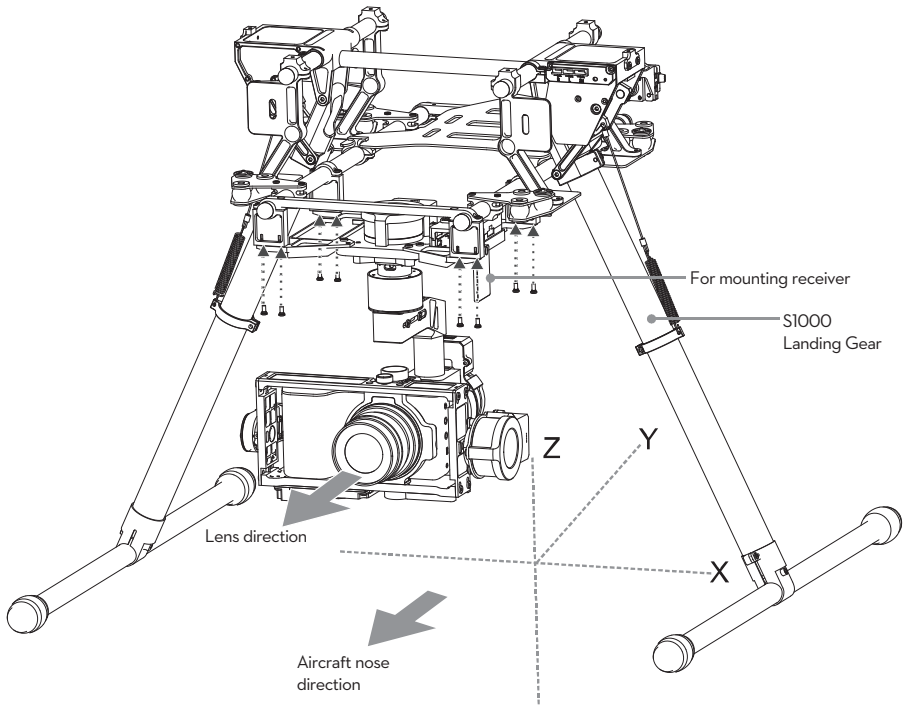

step5: Install gimbal on landing gear with mounting brackets. Tighten screws and use thread lock.



- Ensure the lens is pointing towards the aircraft nose.
- Make sure the top and bottom plates of the damping unit stay parallel when mounting. Prevents stretching and distortion.
- Keep overall balance when mounting in order to make sure the center of gravity is balanced on each of the three axis lines.
- The gimbal's center of gravity has been set from the factory. The center of gravity position directly determines the gimbal's overall performance. Do not adjust the gimbal's center of gravity by yourself.
- The gimbal is highly precise and depends on this precision for the most optimal performance. Do not remove any screws on the gimbal which may result in inferior performance or even damage to the gimbal itself.
- Do not unplug any cables attached to the gimbal ports or change the mechanical structure.
- Make sure the wiring is correct, otherwise, it may lead to abnormal gimbal operation.

Camera Wiring/Record Control

Camera Wiring

An HDMI-HD/AV module converts the video signal format and transforms a TX signal into a record control signal. Carry out the following procedures to connect the camera to the gimbal.

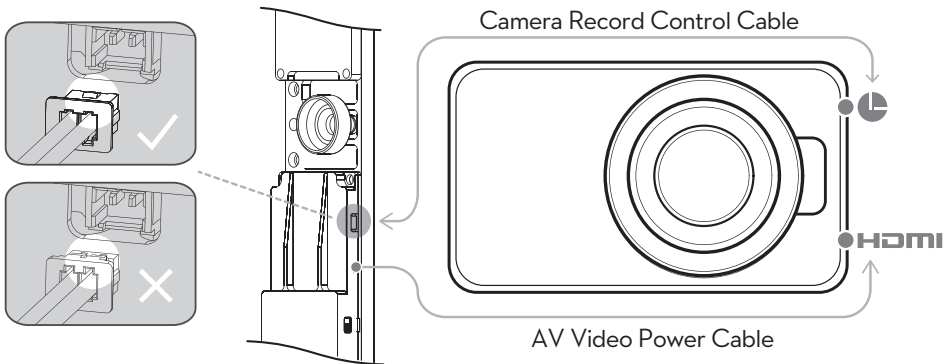

step1: Connect gimbal HDMI-HD/AV module to camera "HDMI OUT" with the AV video power cable.

step2: Connect camera record control cable to the camera's LANC REMOTE CONTROL port.

step3: Toggle the HD/AV Switch to the AV position if using a normal wireless video transmitter module. Toggle the HD/AV Switch to the HD position if using a DJI HD wireless video transmitter module.



Remove the camera from the gimbal before disconnecting the cable between the HDMI-HD/AV module and camera.

Record Control

The Z15-BMPCC translates a TX command to a record control signal to start and stop a recording. Set a 2-position switch/channel for remote record control.

Make sure the record control cable is correctly connected.

Whichever 2-position switch on your transmitter is selected, connect the right channel of receiver to the AUX3 port. One of the two switch positions is to start recording and the other is to stop recording.

Position-1→Position -2: Start recording
Position-2→Position -1: Stop recording

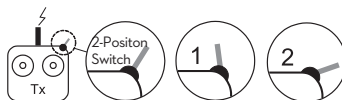



- When the AUX3 port is connected to a PPM channel, it is used as a PPM channel input.
- The following diagram shows how the record control works.
- If the record control works abnormally, check each step.

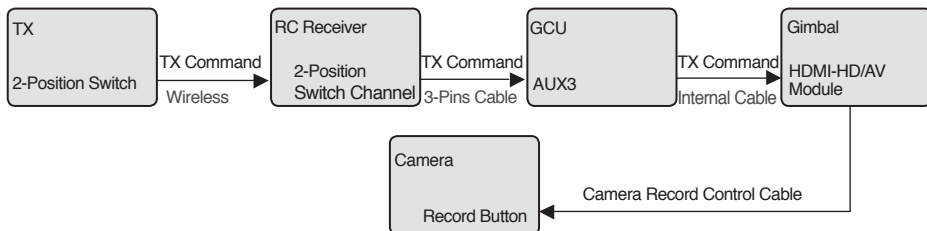

Video Signal Transmission

A wireless video transmission module is required for remote video.

A.AV wireless video transmission

Wireless Video Transmission Module

Air Unit

Connect to the power source according to the module's voltage and current requirements.

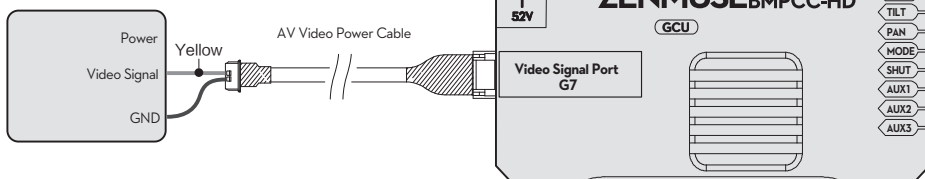

step1: Solder the corresponding Video Signal/GND cables to a wireless video transmission module (Air Unit).

step2: Plug the AV video power cable lead into the GCU's G7 port.

step3: Toggle the HD/AV switch to the AV position.

step4: Power on the gimbal. If the gimbal LED indicator blinks yellow it is functioning normally. If the LED indicator shows solid yellow, the video signal is lost. Check the connections between the camera and the HDMI video input.



- Make sure to connect the wireless video transmission module to the GCU prior to powering on.
- The standard AV video power cable is recommended.
- Make sure you solder the AV to the wireless video transmission module correctly. As the cable carries power, ensure the cables are insulated or wrapped to prevent any type of short circuit. Video signal is connected via "Yellow" line. GND is connected via "Brown" line.
- Connect the wireless video transmission module to a power source as the GCU cannot supply power. Make sure the power is a safe voltage for your own devices according to the wireless video transmission module's requirements.

B.DJI iOSD Mark II and AV wireless video transmission

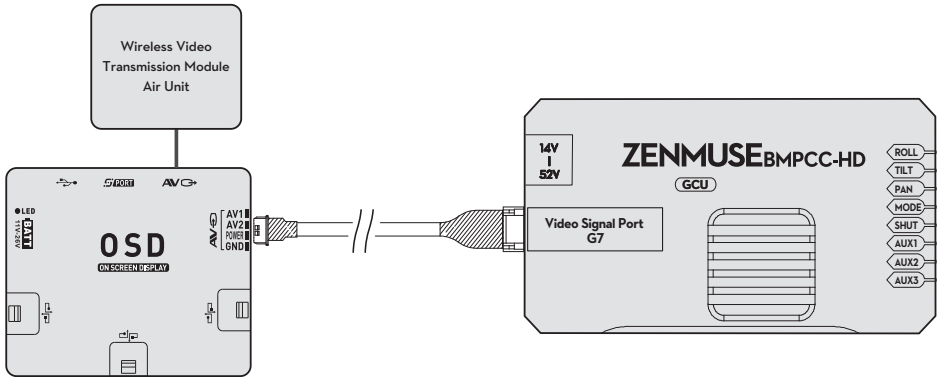

step1: Connect the iOSD Mark II cable leads to the GCU's G7 port.

step2: Complete other connections with iOSD Mark II and wireless video transmission module according to their manuals.

step3: Toggle HD/AV switch to the AV position.

step4: Power on the gimbal. If the gimbal LED indicator blinks yellow it is functioning normally. If the LED indicator shows solid yellow, the video signal is lost. Check the connections between the camera and the HDMI video input.



- Make sure to connect the wireless video transmission module and iOSD MarkII to the GCU prior to powering on.

C.DJI Lightbridge Air System

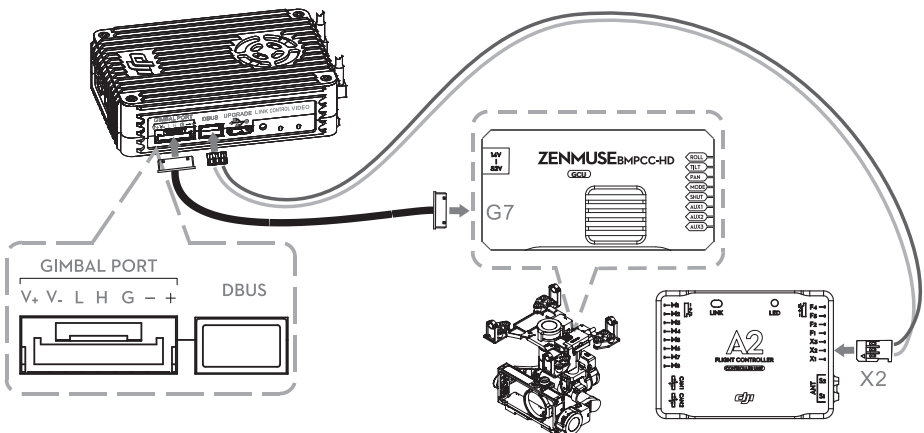

This example is based on a DJI Zenmuse-BMPCC gimbal and A2 flight control system.

- step1: Connect Gimbal Port on air system to G7 port on DJI HD gimbal with supplied Gimbal cable (DJI HD gimbal).
- step2: Connect DBUS port on air system to DBUS port (X2 port) on flight control system. Toggle the HD/AV switch to the HD position.
- step3: Refer to gimbal and flight control system manuals to complete connection.



- HD video power cable is included with BMPCC-HD gimbal. Transmit the signal of your aircraft, connect the RC receiver to the DJI Lightbridge ground system at the same time that the GCU is connected.
- Always connect wireless video transmission module to GCU prior to powering on.
- Standard HD video power cable is recommended.
- Finish off the other connections according to DJI Lightbridge user manual.
- If the gimbal LED indicator continually blinks red, power cycle the gimbal.



- The following diagram shows how a video signal is transmitted from the gimbal.
- If the video signal does not transmit, check through each step.

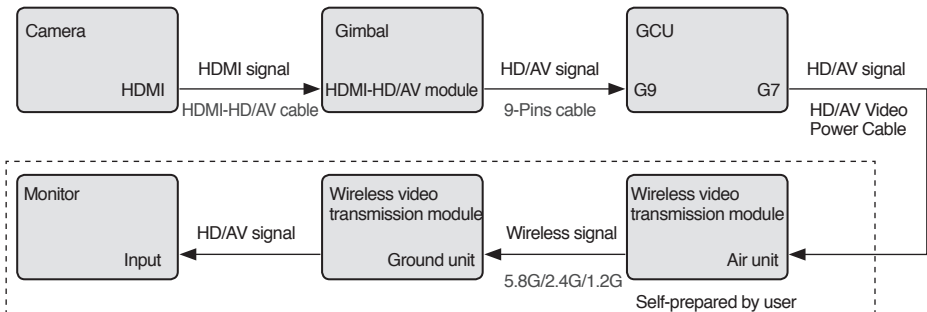

GCU Wiring

For WKM, connect to any spare CAN-Bus port of the flight control system via a CAN-Bus cable.
 For A2, connect to the port labeled CAN1, located on the A2 Controller unit or the CAN port located on any modules which are already connected to the CAN1 port via a CAN-Bus cable.

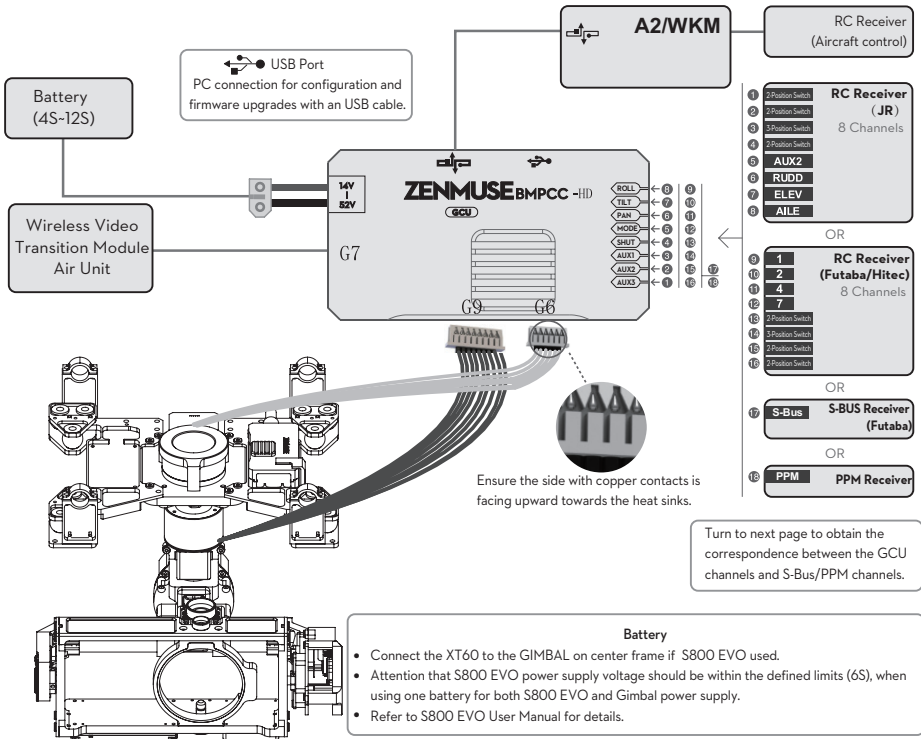

A2 / WKM

• Please refer to A2/WKM User Manual for all connection and configuration details.

Gimbal Controller Unit (GCU)

- Make sure the ports are accessible when installing the GCU so as to facilitate wiring and software configuration.
- In 3-pin ports, pins near the nicks are signal pins.
- 6-pin cable for G6, 9-pin cable for G9.
- DO NOT cover the heat sinks, keep them unobstructed.
- The GCU module is NOT water-proof or oil-proof.



RC Receiver

- These are example connections. The signal of The aircraft will transmit through the DJI Lightbridge ground system. After connecting to the DJI Lightbridge, then it is not necessary to connect with the RC receiver.
- Prepare 2 TXs, one for gimbal control, the other for aircraft control, refer to the 2-Pilots Solution in the Appendix .
- If one receiver is used for aircraft and gimbal control at the same time, please refer to the 1-Pilot Solution section of the Appendix for more details.
- Set Aileron, Elevator, Rudder channels on gimbal control TX. Command stick stands for gimbal rotation velocity, center position is 0, endpoint for maximum velocity (both clockwise and counter clockwise) is 100%.
- Choose one 3-position switch/channel as Z15-BMPCC working modes switch (MODE).
- Choose one 2-position switch/channel as the camera record control switch (AUX3) as a camera lens orientation switch in Reset Mode (AUX2), and one 3-position switch/channel as a camera aperture switch (AUX1).
- Please refer to A2/WKM User Manual for aircraft settings. Connect the receiver to GCU correctly.

GCU Ports Indication

The following table shows the GCU channels and TX channels connection.

TX Channels		GCU Channels	Indications
JR	Futaba/Hitec		
AILE	1	ROLL	Roll axis control (left/right). Velocity is zero if no input provided.
ELEV	2	TILT	Tilt axis control (front/back). Velocity is zero if no input provided.
RUDD	4	PAN	Pan axis control. Velocity is zero if no input provided.
AUX2	7	MODE	Working Mode switch.
---		SHUT	Reserved channel.
3-position switch channel		AUX1	Camera aperture adjust.
2-position switch channel or Futaba S-Bus channel		AUX2	When the AUX2 port is connected to a 2-position switch channel, it is used as camera orientation (down or forward) switch in FPV (Reset). The camera orientation is forward when not connected or no input is provided. If S-Bus receiver is used, it should be connected to the AUX2 port.
2-position switch channel or PPM channel		AUX3	Camera record control. Default is off when not connected or no input is provided. If a PPM receiver is used, it should be connected to the AUX3 port.

The following table shows the corresponding relationship between the GCU and the S-Bus/PPM channels.

S-Bus/PPM Channels	GCU Channels	S-Bus/PPM Channels	GCU Channels
1	ROLL	5	SHUT
2	TILT	8	AUX1
4	PAN	3	AUX2
7	MODE	6	AUX3

Working Modes/AUX1/AUX2 Switch Setup

Working Mode Switch Set

Whichever 3-position switch is selected as the working mode switch, wire the correct channel from the receiver to the MODE port. At each switch position, use end-point fine tuning to set channel AUX2(JR)/7(Futaba/Hitec) for the three Working modes.

Orientation-locked	MODE channel end-point 60%~90%
FPV (Reset)	back to center
Non orientation-locked	MODE channel end-point 60%~90%



- The gimbal will work in Orientation-locked mode, if not connected to MODE channel.
- FPV mode is default.
- The Working Mode from the previous power cycle will be retained if the cable between MODE and RC receiver is disconnected during operation.



- For a 3-position switch, you may assign:

Position-1 to Non orientation-locked

Position-2 to FPV Mode (Reset)

Position-3 to Orientation-locked

Position-1 and Position-3 can be inversely assigned.

- One 2-position switch can be assigned for any two of the working modes as preferred.



AUX1 Switch Set

This product supports remote aperture adjustments. Connect the correct channel of receiver to AUX1 port. Assign: Position-1 to Add; Position-3 to Reduce; or reverse.

One of the two switch positions (Position-1) is to add camera aperture and the other (Position-3) is to reduce camera aperture.

Toggling the switch will do the following.

Position-2 → Position -1: Increase aperture

Position-2 → Position -3: Decrease aperture



AUX2 Switch Set

The Z15-BMPCC supports two camera positions in Reset Mode, straight down and forward. Connect the correct receiver channel to AUX2 port. Assign: Position-1 to DOWN; Position-2 to FORWARD; or the opposite.

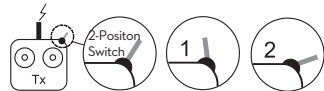

- This function will only work in FPV mode (Reset).
- If the working mode is switched to FPV (Reset) when this is activated, the camera lens will move to face forward or down depending on the AUX2 Switch.
- Camera orientation defaults to facing forward if disconnected during use.



- When the AUX2 port is connected to a S-Bus channel, it is used as a S-Bus channel input.

Assistant Software Installation and Usage

step1: Ensure the driver is installed correctly. This should have been installed before using A2 or WKM software.

step2: Download Assistant installer from DJI.com.

step3: Double click Assistant installer file and follow the steps to finish installation.

step4: Run Assistant.

step5: Upgrade firmware or configure parameters according to Assistant if necessary.

Note: The installer is supported on Win XP, Win7, Win8 (32 or 64 bit).

Pre-Flight Check

Check Before Each Flight



- Gimbal is properly installed and attached to landing gear and the camera is mounted correctly and securely.
- Before powering on, spin the gimbal by hand through the complete rotational axes to ensure nothing is blocking its movement.
- All cables are connected correctly without any plugged in backwards or into the wrong ports.
- AV video power cable is properly soldered and shielded if an AV video transmission module is used.
- Verify transmitter settings.
- Camera record control cable is correctly mounted.
- Camera menu options and settings are correct.
- A proper connection between GCU and RC receiver.
- A proper connection between GCU and flight control system.
- Latest Flight Control System MC Firmware is installed.



- Refer to the Gimbal LED Indicator section in the Appendix for understanding the connection status between the camera and gimbal.
- Refer to the Trouble Shooting section in the Appendix if an abnormal situation occurs.

Flight Test

step1: Ensure batteries are fully charged for your TX, GCU and all the other devices on your aircraft.

step2: Make sure all connections and wiring are in good condition.

step3: Switch on the TX.

step4: Adjust camera position on the roll axis of gimbal to level before powering on.

- step5: Power on the gimbal and wait for the self initialization test to complete. The roll, yaw and pitch axes will rotate quickly at the same time.
- step6: After self initialization, the camera lens will point towards the aircraft's nose and the three axis gimbal should be in the position as illustrated in the above diagram.
- step7: The gimbal goes into a second stage initialization. At this time the three axes will start to rotate very slowly.
- step8: The gimbal is at a standstill after initialization and ready to use.
- step9: Toggle the assigned Working Modes switch on your transmitter and make sure it is working properly.
- step10: Switch the Working Modes to Non orientation-locked, FPV Mode (Reset), Orientation-locked Mode respectively. Then try to push your sticks lightly in the Roll, Tilt and Pan directions to feel if your gimbal moves in the corresponding directions. If not, go back to the Gimbal Working Mode Switch Set to correct your settings.

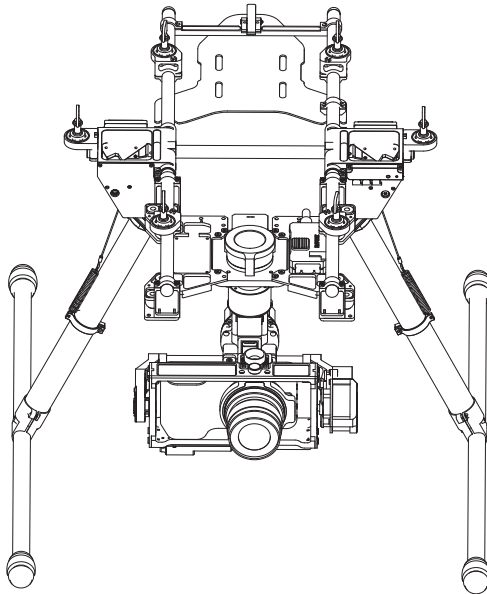

- If the gimbal is abnormal (unlike the diagram shows) after initialization, please refer to the Trouble Shooting section in Appendix.

Appendix

Attention

For safety reasons, please pay serious attention to all of the following items:

- To avoid motor damage ensure nothing blocks the servo drive module's total range of movement.
- Before powering on, spin the gimbal by hand through the complete rotational axes to ensure nothing is blocking the mechanical movement of the gimbal.
- Be sure to mount the side of servo drive module1 with ports facing towards the aircraft tail.
- The gimbal's center of gravity balance has been preset. The gimbal balance is directly correlated with the gimbal performance. Please do not adjust the gimbal's center of gravity by yourself.
- The gimbal is a sophisticated device. Do not remove any other screws from the gimbal which may result in poor performance or even damage.
- Do not unplug any cables attached to the gimbal ports or change the mechanical structure.
- Make sure all wiring is correct, otherwise it may lead to abnormal operation or the gimbal may not operate efficiently.
- Make sure to connect the wireless video transmission module to the GCU prior to powering on the system.
- The factory AV video power cable is recommended.
- Make sure you solder the AV video power cable to the wireless video transmission module correctly. Ensure the cables are insulated and protected to prevent any type of short circuit.
- Pay close attention to the voltage of S800 EVO/S1000 and be sure it is within the defined limits (6S) when using one battery for both the S800 EVO/S1000 and power supply for the gimbal.
- Prevent the gimbal from ever touching the contact points of a power cable; otherwise it may lead to a short circuit of the gimbal, resulting in complete failure.
- Before powering on, adjust the roll axis of the gimbal to be level when the camera is attached.

1-Pilot Solution

- This is an example of the wiring configuration. Prepare one 14-channel Transmitter/RC receiver for the aircraft and gimbal control.
- Setup the Aileron, Elevator, Throttle, and Rudder channels on Transmitter for the aircraft's roll, elevator, throttle, and rudder control. Also connect the Transmitter's AUX2 for aircraft control modes (Please refer to the Flight Control System User Manual).
- Choose three 3-position switches for gimbal's ROLL, TILT, and PAN rotation control. The switch at center position is 0 velocity and at the end point position is at maximum velocity.
- Choose one 3-position switch/channel as the gimbal's Working Modes switch (MODE).
- Choose one 2-position switch/channel as the camera record control switch (AUX3).
- Choose one 3-position switch/channel as the camera aperture control switch (AUX1).
- Connect the receiver to GCU and Flight Control System MC correctly.

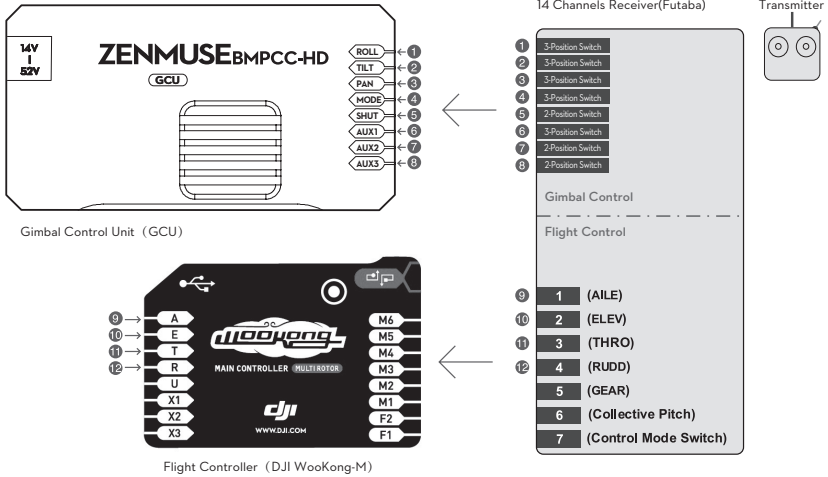

2-PILOT SOLUTION

- Two transmitters and two receivers are required.
 - Transmitter A and receiver A are used on controlling gimbal.
 - Transmitter B and receiver B are used on controlling aircraft.
- Connection diagram shown as below:

Gimbal Control

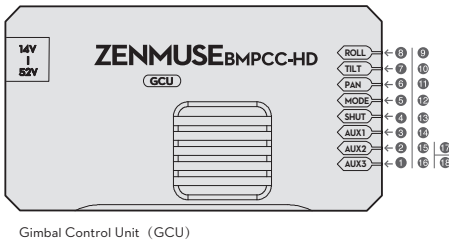

Gimbal Control Unit (GCU)

Flight Controller



RC Receiver B



OR

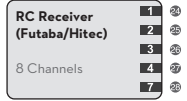

OR



DJI WooKong-M Flight Controller

RC Receiver A

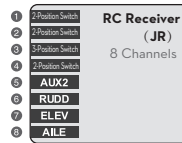

OR

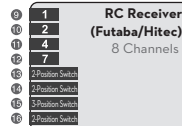

OR

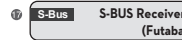

OR

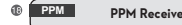



Transmitter A



Port Description







GCU

ROLL	For roll axis control	
TILT	For tilt axis control	
PAN	For pan axis control	
MODE	For Working Mode switch	
SHUT	Reserved channel	
AUX1	For camera aperture control	
AUX2	For Gimbal orientation (down or forward) switch in FPV Mode	S-Bus Receiver
AUX3	For camera record control	PPM Receiver
G7	1. To wireless video transmission module, transmitting AV or HD signals 2. To DJI Lightbridge, transmitting HD and aircraft control signals	
XT60	To battery (To GIMBAL if DJI S800 EVO used)	
G6	To Gimbal, transmitting motor command	
G9	To Gimbal, transmitting video signal	
	Micro-USB port: PC connection for configuration and firmware upgrades	
	CAN-Bus port: Use CAN-Bus to connect GCU to the Flight Control System	

Gimbal

HDMI-HD/AV Port	To camera HDMI port
Motor Command Input Port	To GCU G6
9-Pin Cable Port	To GCU G9

Gimbal LED Indicator

Description	LED Indicator
HD mode, HDMI-HD/AV module transmits normally	 LED is blinking green.
HD mode, without camera HDMI video input	 Green LED is solid on.
HD mode, DJI Lightbridge App video source has been set to "HDMI/AV"	 Yellow LED is solid on.
AV mode, HDMI-HD/AV module transmits normally	 LED is blinking yellow.
AV mode, without camera HDMI video input	 Yellow LED is solid on.
HD video transmission module and gimbal is disconnected	 LED is blinking red.

Trouble Shooting

NO.	What	Why	How to
1	The gimbal keeps drifting after initialization.	(1) The TX trims are too high. (2) The GCU and Flight Control System have been disconnected. (3) The gimbal mounting direction is not pointing towards the aircraft's nose.	(1) Adjust the TX trims. (2) Connect the GCU and Flight Control System. (3) Ensure the gimbal mounting direction is the same with aircraft's nose.
2	The gimbal is abnormal after initializing.	Abnormal calibration after manufacturing.	Please contact the local dealer or DJI customer service.
3	Cannot distinguish the gimbal's direction when in use.	BVR (Beyond Visibility Range) flight.	Switch to the FPV Mode first, then to another Working Mode as needed.
4	The gimbal LED is blinking red.	(1) There is a disconnection between the gimbal and camera. (2) Camera is off. (3) Camera setup failure.	(1) Make sure the cables are securely connected. (2) Power on the camera. (3) Set the HDMI resolution to 1080i.
5	The gimbal's green or yellow LED is solid on but no video displayed.	(1) HDMI-HD/AV transmission module is disconnected from camera. (2) The camera is power off. (3) HD mode, DJI Lightbridge APP video source has been set to "HDMI/AV".	(1) Check HDMI-HD/AV transmission module connection. (2) Power on the camera. (3) Change the DJI Lightbridge App video source to "HD Gimbal".

Specifications

General

Built-In Functions	<ul style="list-style-type: none"> • Three Modes <ul style="list-style-type: none"> Orientation-locked Non orientation-locked FPV mode (Reset) • Built-in independent IMU module • DJI-designed servo drives 	<ul style="list-style-type: none"> • HDMI-HD/AV module • Wireless video transmission module support • Camera record control support • Wide range voltage input support • S-Bus/PPM Receiver support
--------------------	---	--

Peripheral

Supported Camera	BMPCC
Supported Lens Currently	OLYMPUS M.ZUIKO DIGITAL ED 12mm f/2.0
GCU Input Power	4S~12S LiPo (Recommend 6S if used with the S800 EVO or S1000)
Control Requirement	Minimum of four spare receiver channels
Assistant Software System Requirement	Windows XP SP3; Windows 7; Windows 8 (32 or 64 bit)

Mechanical& Electrical Characteristics

Working Current	<ul style="list-style-type: none"> • Static current: 200mA (@25V) • Dynamic current: 400mA (@25V) • Locked-rotor current: 1.8A (@25V)
-----------------	--

Operating Temperature	-10°C ~ 50°C
-----------------------	--------------

Weight	1.26Kg
--------	--------

Dimensions	227mm(H) × 212mm(D) × 210mm(W)
------------	--------------------------------

GCU Weight	63g
------------	-----

GCU Dimensions	64.2 mm × 34.1mm × 19.5mm
----------------	---------------------------

Working Performance

Load Weight (Reference Value)	487g(@BMPCC with OLYMPUS M.ZUIKO DIGITAL ED 12mm f2.0, Battery and SD-Card)
-------------------------------	---

Controlled Angle Accuracy	0.01°
---------------------------	-------

Maximum Controlled Rotation Speed*	Pan axis: ±130°/s Tilt axis: ±130°/s Roll axis: ±30°/s
------------------------------------	--

Controlled Rotation Range	Pan axis control: ±360° continuous rotation Tilt axis control: +50°/-140° Roll axis control: ±40°
---------------------------	---

Note*: Gimbal's Maximum Controlled Rotation Speed corresponds to TX stick input pushed to 100% end-points.

User manual is subject to change without prior notice.

You may visit DJI official website to obtain the latest version of user manual.

<http://www.dji.com/product/zenmuse-z15-bmpcc/download>